

**NATIONAL REPORT ON THE IMPLEMENTATION  
OF THE UNITED NATIONS PROGRAM OF ACTION  
TO PREVENT, COMBAT AND ERADICATE  
THE ILLICIT TRADE IN SMALL ARMS AND LIGHT WEAPONS  
IN ALL ITS ASPECTS,**

**Submitted by  
the Federal Republic of Germany**

**Berlin  
April 30, 2005**

241-370.27/3.8

### Missive

With reference to the letter of the United Nations Department for Disarmament Affairs dated February 14, 2005—DDA/06-2005/TSA—, the Federal Republic of Germany hereby submits her National Report on the Implementation of the United Nations Program of Action to Prevent, Combat and Eradicate the Illicit Trade in Small Arms and Light Weapons in All Its Aspects.

She agrees to the publication of the entire report on the homepage of the United Nations Department for Disarmament Affairs.

Berlin, April 30, 2005

© 2005 Federal Foreign Office (*Auswaertiges Amt*)—Division 241

Federal Foreign Office (*Auswaertiges Amt*)  
Division 241  
11013 BERLIN  
GERMANY

Telephone +49 30 50 00 14 65  
Facsimile +49 30 500 05 14 65  
Email [241-1@diplo.de](mailto:241-1@diplo.de)

## TABLE OF CONTENTS

<b>ABBREVIATIONS</b>	<b>9</b>
<b>1 NATIONAL LEVEL</b>	<b>10</b>
<b>1.1 National Coordination Agency and National Point of Contact</b>	<b>10</b>
1.1.1 <i>Does your country have a national coordination agency or body that is responsible for policy guidance, research and monitoring of efforts to prevent, combat and eradicate the illicit trade in SALW in all its aspects?</i>	10
1.1.2 <i>Does your country have a national point of contact to act as liaison with other States on matters relating to the implementation of the U.N. Program of Action?</i>	10
<b>1.2 Legislation, Regulations, and Administrative Procedures</b>	<b>10</b>
1.2.1 <i>What national laws, regulations and administrative procedures exist to exercise effective control over SALW in the areas of production, export, import, transit, retransfer?</i>	10
1.2.1.1 RELEVANT STATUTORY INSTRUMENTS	10
1.2.1.2 STATUTORY DICHOTOMY “WAR WEAPONS”—“OTHER MILITARY EQUIPMENT”	11
1.2.1.2.1 War Weapons	12
1.2.1.2.2 Other Military Equipment	13
1.2.2 <i>What national measures exist to prevent the manufacture, stockpiling, transfer and possession of unmarked or inadequately marked SALW? How have these been implemented?</i>	13
1.2.2.1 INTRODUCTORY REMARKS	FEHLER! TEXTMARKE NICHT DEFINIERT.
1.2.2.2 MANUFACTURE	13
1.2.2.3 STOCKPILING	13
1.2.2.4 TRANSFER AND RETRANSFER	14
1.2.2.5 POSSESSION	14
1.2.3 <i>Please describe how national laws, regulations and procedures that impact on the prevention, combating and eradication of the illicit trade in SALW in all its aspects are made public</i>	14
<b>1.3 Law Enforcement and Criminalization</b>	<b>14</b>
1.3.1 <i>What national legislative or other measures exist to make the illegal manufacture, possession, stockpiling and trade of SALW criminal offenses under domestic law? How have these measures been implemented?</i>	14
1.3.2 <i>Have those groups and individuals engaged in the illegal manufacture, trade, stockpiling, transfer, possession, as well as financing for acquisition, of illicit SALW been identified, where applicable? What action has been taken under appropriate national law against such groups and individuals?</i>	16
1.3.3 <i>What national measures have been taken, including legal or administrative means, against activity that violates a United Nations Security Council arms embargo in accordance with the Charter of the United Nations?</i>	16
<b>1.4 Stockpile Management and Security</b>	<b>17</b>

1.4.1	<i>What national standards and procedures exist for the management and security of SALW stocks held by armed forces, police or other authorized bodies?</i>	17
1.4.1.1	FEDERAL ARMED FORCES	17
1.4.1.2	FEDERAL AND STATE POLICE FORCES	17
1.4.2	<i>How often are stocks of SALW held by armed forces, police and other authorized bodies reviewed?</i>	17
1.4.2.1	FEDERAL ARMED FORCES	17
1.4.2.2	FEDERAL AND STATE POLICE FORCES	18
1.4.3	<i>How are those stocks of SALW held by armed forces, police and other authorized bodies that are surplus to requirements identified?</i>	18
1.4.3.1	FEDERAL ARMED FORCES	18
1.4.3.2	FEDERAL AND STATE POLICE FORCES	18
1.4.3.3	FEDERAL CUSTOMS ADMINISTRATION	18
<b>1.5</b>	<b>Collection and Disposal</b>	<b>19</b>
1.5.1	<i>Please give details of any national programs that have been established and implemented for the responsible disposal of surplus stocks of SALW held by armed forces, police and other authorized bodies</i>	19
1.5.1.1	FEDERAL ARMED FORCES	19
1.5.1.1.1	Introductory Remark	19
1.5.1.1.2	Techniques for Destruction	19
1.5.1.1.3	Details on Recordkeeping, Authority for Destruction, and Destruction Sites	19
1.5.1.1.4	Seized or Confiscated Weapons	19
1.5.1.1.5	Surplus Weapons 1990—2004	20
1.5.1.2	FEDERAL BORDER POLICE	20
1.5.1.3	FEDERAL CUSTOMS ADMINISTRATION	20
1.5.2	<i>Is destruction the means used to dispose of such stocks?</i>	20
1.5.2.1	FEDERAL ARMED FORCES	20
1.5.2.2	FEDERAL AND STATE POLICE FORCES	20
1.5.2.3	FEDERAL CUSTOMS ADMINISTRATION	21
1.5.3	<i>What national measures exist to safeguard such stocks prior to their disposal?</i>	21
1.5.3.1	FEDERAL ARMED FORCES	21
1.5.3.2	FEDERAL AND STATE POLICE FORCES	21
1.5.3.3	FEDERAL CUSTOMS ADMINISTRATION	21
1.5.4	<i>Subject to the exceptions set out in UNPoA II:16, are all confiscated, seized or collected SALW destroyed?</i>	21
1.5.4.1	FEDERAL ARMED FORCES	21
1.5.4.2	FEDERAL AND STATE POLICE FORCES	21
1.5.4.3	FEDERAL CUSTOMS ADMINISTRATION	21

1.5.5	<i>What methods has your country used to destroy surplus stocks of SALW designated for destruction? (If appropriate, please make reference to the report of the U.N. Secretary-General [S/2000/1092] of November 15, 2000)</i>	22
1.5.5.1	FEDERAL ARMED FORCES	22
1.5.5.2	FEDERAL AND STATE POLICE FORCES	22
1.5.5.3	FEDERAL CUSTOMS ADMINISTRATION	22
1.5.6	<i>Please give details of any information on SALW confiscated or destroyed within your jurisdiction that is submitted to relevant regional and international organizations</i>	22
1.5.6.1	INTRODUCTORY REMARKS	22
1.5.6.2	FEDERAL ARMED FORCES	22
1.5.6.3	FEDERAL AND STATE POLICE FORCES	23
1.5.6.4	FEDERAL CUSTOMS ADMINISTRATION	23
<b>1.6</b>	<b>Export Controls and Brokering Controls</b>	<b>23</b>
1.6.1	<i>Please describe the system of export and import licensing or authorization, as well as measures on international transit, used by your country for the transfer of all SALW</i>	23
1.6.1.1	INTRODUCTION INTO GERMAN EXPORT CONTROL POLICY	23
1.6.1.2	TYPES OF LICENSES FOR FINAL EXPORTS	24
1.6.1.2.1	Individual Licenses and Maximum Amount Licenses	24
1.6.1.2.2	Collective Export Licenses	25
1.6.1.2.3	General Licenses	25
1.6.1.3	LICENSES FOR TEMPORARY EXPORTS	25
1.6.1.4	PERIOD OF VALIDITY OF LICENSES	25
1.6.1.5	LICENSING AUTHORITY AND LEGAL RECOURSE	26
1.6.1.5.1	War Weapons	26
1.6.1.5.2	Other Military Equipment	26
1.6.1.6	CIRCUMSTANCES IN WHICH A LICENSE IS NOT REQUIRED	26
1.6.1.7	REVOCATION OF LICENSES	26
1.6.1.8	EMBARGOED DESTINATIONS AND AREAS OF CONCERN	27
1.6.1.9	ADVANCE RULINGS	27
1.6.2	<i>Please describe the national laws, regulations and administrative procedures used by your country to ensure effective control over the export and transit of SALW. How are these measures implemented?</i>	27
1.6.3	<i>Does your country use authenticated end-user certificates for this purpose?</i>	28
1.6.4	<i>Does your country notify the original exporting State when re-exporting or retransferring previously imported SALW?</i>	29
1.6.5	<i>What national legislation or administrative procedures exist to regulate the activities of those who engage in SALW brokering within national jurisdiction and control? (e.g. registration of brokers, licensing or authorization of brokering transactions and appropriate penalties)</i>	29
1.6.5.1	LICENSES, REGISTRATION AND REPORTING	29
1.6.5.2	CRIMINALIZATION OF ILLEGAL INTERNATIONAL BROKERING ACTIVITIES	30

1.6.5.3 EXPORTER NOT REQUIRED TO DISCLOSE BROKERS INVOLVED IN TRANSACTION _____	31
1.6.5.4 NUMBER OF REVOCATIONS OR DISBARMENT OF INTERNATIONAL BROKERS ____	31
<b>1.7 Marking, Recordkeeping and Tracing _____</b>	<b>31</b>
1.7.1 <i>Does your country require licensed manufacturers of SALW to apply an appropriate and reliable marking on each weapon as an integral part of the production process? Is this marking unique?</i> _____	31
1.7.1.1 INTRODUCTORY REMARKS _____	31
1.7.1.2 FEDERAL ARMED FORCES _____	31
1.7.1.3 FEDERAL AND STATE POLICE FORCES _____	32
1.7.1.4 FEDERAL REVENUE ADMINISTRATION _____	32
1.7.2 <i>Does this marking identify the country of manufacture?</i> _____	32
1.7.3 <i>How does this marking otherwise allow concerned authorities to identify and trace the relevant weapon?</i> _____	32
1.7.4 <i>How long are records kept on the manufacture, holding and transfer of SALW under your jurisdiction?</i> _____	33
1.7.5 <i>What national measures exist for tracing SALW held and issued by the State?</i> _____	33
1.7.6 <i>Please give details of any steps taken by your country to cooperate in tracing illicit SALW, including the strengthening of mechanisms based on the exchange of relevant information</i> _____	33
1.7.6.1 FEDERAL ARMED FORCES _____	33
1.7.6.2 FEDERAL AND STATE POLICE FORCES _____	34
1.7.6.3 FEDERAL CUSTOMS ADMINISTRATION _____	34
<b>1.8 Disarmament, Demobilization and Reintegration (DD&amp;R) _____</b>	<b>34</b>
<b>1.9 Awareness-Raising _____</b>	<b>35</b>
<b>2 REGIONAL LEVEL _____</b>	<b>35</b>
<b>2.1 Legally Binding Instruments _____</b>	<b>35</b>
2.1.1 <i>Has your country been involved in negotiations for the conclusion of legally binding instruments aimed at preventing, combating and eradicating the illicit trade in SALW in all its aspects?</i> _____	35
2.1.2 <i>Where such instruments exist, please describe the steps your country has taken to ratify and fully implement them</i> _____	36
<b>2.2 Moratoria and Action Programs _____</b>	<b>36</b>
<b>2.3 Regional Cooperation _____</b>	<b>36</b>
2.3.1 <i>Please describe any involvement your country has had in the establishment of subregional or regional mechanisms with a view to preventing, combating and eradicating the illicit trade in SALW across borders (in particular trans-border customs cooperation and networks for information-sharing among law enforcement, border and customs control agencies)</i> _____	36

2.3.2	<i>Please describe any initiatives your country has undertaken to encourage regional and subregional action on illicit trade in SALW in all its aspects in order to, as appropriate, introduce, adhere, implement or strengthen relevant laws, regulations and administrative procedures</i>	37
<b>3</b>	<b>GLOBAL LEVEL</b>	<b>37</b>
<b>3.1</b>	<b>International Instruments Against Terrorism and Organized Crime</b>	<b>37</b>
<b>3.2</b>	<b>International Cooperation and Assistance</b>	<b>39</b>
3.2.1	<i>Please give details of any assistance, including technical and financial assistance, your country has provided for purposes of supporting the implementation of the measures to prevent, combat and eradicate the illicit trade in SALW in all its aspects as contained in UNPoA</i>	39
3.2.2	<i>Please describe any initiatives your country has undertaken to enhance mutual legal assistance and other forms of cooperation in order to assist investigations and prosecutions in relation to the illicit trade in SALW in all its aspects</i>	39
3.2.3	<i>Please give details of any assistance your country has provided to combat the illicit trade in SALW linked to drug trafficking, transnational organized crime and terrorism</i>	39
3.2.4	<i>Please give details of your country's cooperation with Interpol for the purpose of identifying those groups and individuals engaged in the illicit trade in SALW in all its aspects</i>	40
3.2.5	<i>Please give details of your country's use and support of Interpol's International Weapons and Explosives Tracking System database (including providing relevant information on the illicit trade in SALW)</i>	40
3.2.6	<i>Please give details of your country's cooperation with the U.N. system to ensure the effective implementation of arms embargoes decided by the U.N. Security Council in accordance with the U.N. Charter</i>	40
3.2.7	<i>Please describe any steps your country has taken in cooperation with other states, or regional or international organizations, to develop common understandings of the basic issues and the scope of the problems related to illicit brokering in SALW</i>	41
<b>3.3</b>	<b>Cooperation with Civil Society and Nongovernmental Organizations</b>	<b>41</b>
<b>3.4</b>	<b>Information Exchange</b>	<b>41</b>
3.4.1	<i>Please describe any steps taken by your country to exchange information on national marking systems on SALW</i>	42
3.4.2	<i>Please give details of any information on, inter alia, SALW confiscated or destroyed within national jurisdiction, or other relevant information such as illicit trade routes and techniques of acquisition, that your country has submitted to relevant regional and international organizations</i>	42
<b>3.5</b>	<b>Training, Capacity-Building, Research</b>	<b>42</b>
3.5.1	<i>Please describe any initiatives your country has undertaken to enhance cooperation and exchange of experience and training among competent officials, including customs, police, intelligence and arms control officials, at the national, regional and global levels in order to combat the illicit trade in SALW in all its aspects</i>	42

3.5.2 *Please describe any regional and international programs for specialist training on small arms stockpile management and security that your country has developed or supported* \_\_\_\_\_ 43

3.5.3 *Please give details of any action-oriented research aimed at facilitating greater awareness and better understanding of the nature and scope of the problems associated with the illicit trade in SALW in all its aspects that your country has developed or supported* \_\_\_\_\_ 43

**ANNEX A POLITICAL PRINCIPLES GOVERNING THE EXPORT OF WAR WEAPONS AND OTHER MILITARY EQUIPMENT, ADOPTED ON JANUARY 19, 2000** \_\_\_\_\_ **44**

**ANNEX B ANALYSIS AND EVALUATION OF INFORMATION AVAILABLE TO THE FEDERAL CRIMINAL POLICE BUREAU ON THEFTS, LOSSES AND SEIZURES OF SALW IN 2004** \_\_\_\_\_ **50**

**ANNEX C NUMBER OF FEDERAL ARMED FORCES SALW DESTROYED IN THE PERIOD FROM 1990 TO 2004** \_\_\_\_\_ **48**

**ANNEX D LOCATION AND SAMPLE OF MARKS** \_\_\_\_\_ **53**



## ABBREVIATIONS

CVAP	Cambodian Veterans Assistance Program
DD&R	Disarmament, Demobilization and Reintegration
EAC	East African Community
ECOWAS	Economic Community of West African States
IWETS	International Weapons and Explosives Tracking System (an Interpol database)
MDRP	Multi-Donor Demobilization and Reintegration Program
OSCE	Organization for Security and Cooperation in Europe
SADC	Southern African Development Community
SALW	Small arms and light weapons
UNPoA	United Nations Program of Action to Prevent, Combat and Eradicate the Illicit Trade in Small Arms and Light Weapons in All Its Aspects

## 1 NATIONAL LEVEL

### 1.1 National Coordination Agency and National Point of Contact

1.1.1 *Does your country have a national coordination agency or body that is responsible for policy guidance, research and monitoring of efforts to prevent, combat and eradicate the illicit trade in SALW in all its aspects?*

#### UNPoA II:4

Germany does not have a single national coordination agency or body as envisaged in the question. In this context,—

- (i) the *Federal Foreign Office* is fulfilling the task of coordinating SALW-related foreign policy aspects, including the task as national point of contact (cf. [§ 1.1.2](#) *infra*);
- (ii) the *Federal Ministry of the Interior* is responsible for the firearms legislation, including the municipal regulation of weapons marking, registration, recordkeeping and sanctioning offenses;
- (iii) the *Federal Ministry of Defense* is responsible for—
  - regulating all issues linked to the marking, registration, recordkeeping, and stockpiling of SALW in use with the Federal Armed Forces,
  - structuring the procurement procedures related to SALW to be used by the Federal Armed Forces;
- (iv) the *Federal Ministry of Economics and Labour* is—
  - coordinating export control and brokering issues,
  - responsible for legislation concerning war weapons and other military equipment;
- (v) the *Federal Ministry for Economic Cooperation and Development* is addressing SALW issues principally implying developmental aspects.

1.1.2 *Does your country have a national point of contact to act as liaison with other States on matters relating to the implementation of the U.N. Program of Action?*

#### UNPoA II:5

Federal Foreign Office (*Auswaertiges Amt*)  
Division 241  
11013 BERLIN  
GERMANY

Telephone +49 30 50 00 14 65  
Facsimile +49 30 500 05 14 65  
Email 241-1@diplo.de

### 1.2 Legislation, Regulations, and Administrative Procedures

1.2.1 *What national laws, regulations and administrative procedures exist to exercise effective control over SALW in the areas of production, export, import, transit, retransfer?*

#### UNPoA II:2

1.2.1.1 RELEVANT STATUTORY INSTRUMENTS

Provisions concerning SALW to be used solely for military purposes are contained in—

- (i) the *Basic Law*, i.e. the Constitution of the Federal Republic of Germany,
- (ii) the *Act Implementing Article 26(2) of the Basic Law (War Weapons Control Act)*, and
- (iii) the *Foreign Trade and Payments Act* in conjunction with the *Foreign Trade and Payments Ordinance*.

In addition, on January 19, 2000, the Federal Government adopted *Political Principles Governing the Export of War Weapons and Other Military Equipment* (hereinafter: “Political Principles”) to provide the licensing agencies with guidelines for the scope of and limits to the discretion open to them. The Political Principles are reproduced as [Annex A](#) *infra*.

Article 26(2) of the *Basic Law* provides that “[w]eapons designed for warfare may be manufactured, transported or marketed only with the permission of the Federal Government. Details will be regulated by a Federal Law.” This constitutional mandate has been put into federal legislation in the *Act Implementing Article 26(2) of the Basic Law (War Weapons Control Act)* of April 20, 1961, as amended.<sup>1</sup>

#### 1.2.1.2 STATUTORY DICHOTOMY “WAR WEAPONS”—“OTHER MILITARY EQUIPMENT”

German law on export of weaponry—including SALW—is consistently structured following a terminological dichotomy.

While the export of so-called “other military equipment” is subject to general foreign trade law outlined in [§ 1.2.1.2.2](#) *infra*, i.e. the rules contained in the *Foreign Trade and Payments Act* and the *Foreign Trade and Payments Ordinance*, it is the *War Weapons Control Act* which specifically governs the law on export of war weaponry. The scope of both terms is defined enumeratively by two different lists, pursuant to which—

- “war weapons” are those defense items contained in the *War Weapons Schedule*, as annexed to section 1(1) of the *War Weapons Control Act*, and
- “other military equipment” are those defense items contained in Part I section A of the *Exports Schedule*, i.e. the Annex to section 5(1) of the *Foreign Trade and Payments Ordinance*.

Applied on the definition of the term “small arms and light weapons” in the footnote to preambulatory paragraph 3 of the *OSCE Document on Small Arms and Light Weapons*, the terminological distinction leads to the following conclusion: Whereas light weapons without exception are covered by items enumerated in the *War Weapons Schedule* and thus always constitute “war weapons,” this is not the case as to revolvers, self-loading pistols, rifles and carbines, even if the weapon in question is made or modified for military use and therefore covered by the small arms definition.

---

<sup>1</sup> 1961 Federal Law Gazette I-444.

Weapons pursuant to the footnote to preambulatory paragraph 3 of the <i>OSCE Document on Small Arms and Light Weapons</i>		<i>War Weapons Schedule</i> item no.
<b>I</b>	<b>SMALL ARMS</b>	
I:A	Revolvers	"Other military equipment," on which the <i>War Weapons</i> <i>Control Act</i> does not apply (cf. <a href="#">§ 1.2.1.2.2</a> <i>infra</i> )
I:B	Self-loading pistols	
I:C	Rifles	
I:D	Carbines	
I:E	Sub-machine guns	29(b)
I:F	Assault rifles	29(c)
I:G	Light machine guns	29(a)
<b>II</b>	<b>LIGHT WEAPONS</b>	
II:A	Heavy machine guns	29(a)
II:B	Hand-held under-barrel grenade launchers	30
II:C	Mounted grenade launchers	30
II:D	Portable anti-aircraft guns	31
II:E	Portable anti-tank guns	31
II:F	Recoilless rifles	31
II:G	Portable launchers of anti-tank missile and rocket systems	10 or 37
II:H	Portable launchers of anti-aircraft missile systems	10
II:I	Mortars of calibers less than 100 mm	31

#### 1.2.1.2.1 War Weapons

The *War Weapons Control Act* stipulates that all handling of "war weapons" requires prior approval; this requirement primarily refers to the manufacture, acquisition and transfer of actual control, to all types of transport (within Germany; import, export and transit), and to deals by intermediaries, even if the war weapons do not enter German territory.

Any manufacturing, acquisition, transport, and transfer of, as well as trade with war weaponry requires a public license to be issued before engaging in these activities. As a rule, these licenses are granted individually for a specific period of time, hereby covering a limited number of pieces. Licenses are only granted after a reliability test, in the course of which the central penal register is consulted. The Federal Ministry of the Interior and the competent ministries in those federal states, where licensable transactions shall take place, have to give their consent prior to the issuance of a license.

Pursuant to section 6 of the *War Weapons Control Act*, there is no legal right to receive a license. Instead, such a license must be refused if there is a danger that the war weapons will be used in a way which disturbs peace, that international commitments entered into by Germany will be violated, or that the applicant is not sufficiently reliable to undertake the envisaged action. Beyond this, the issuance or refusal of an export license is subject to the political discretion of the Federal Government, and it uses its discretion in line with the "Political Principles" of January 19, 2000.

The validity of the license depends on the type of transaction. Thus, a transport license normally will have a shorter validity than a manufacturing license. German law as it stands knows of no licenses which are unlimited in time.

As lawmaking in the field of war weaponry is a matter of exclusive federal legislation, the federal states (*Länder*) have the right to legislate in matters concerning SALW not designed as war weapons only to the extent the Federal Republic has refrained from legislating on the federal level; Article 74(1)(4a) of the *Basic Law*.

After the entry into force, on April 1, 2003, of the most recent amendment to the *Weapons Act*, the federal states will practically only retain the right to legislate on state police SALW issues and on the administration of non-military SALW recordkeeping, where a parallel system applies with a federal back-up register of SALW maintained by the Federal Border Police and local registers on non-military SALW ownership.

#### 1.2.1.2.2 Other Military Equipment

The export of so-called “other military equipment” is subject to the rules contained in the *Foreign Trade and Payments Act* and the *Foreign Trade and Payments Ordinance*. The applicant has a right to receive an export license unless a license would entail a violation of section 7 of the *Foreign Trade and Payments Act* (cf. [§ 1.2.1.1 supra](#)) by—

- jeopardizing the security of the Federal Republic of Germany,
- disrupting the peaceful coexistence of nations, or
- considerably disrupting Germany’s foreign relations.

The “Political Principles” of January 19, 2000, apply equally on “other military equipment.”

1.2.2 *What national measures exist to prevent the manufacture, stockpiling, transfer and possession of unmarked or inadequately marked SALW? How have these been implemented?*

### UNPoA II:8

#### 1.2.2.1 MANUFACTURE

Provisions establishing obligations to mark *war weapons* are contained in section 12(7)(3) of the *War Weapons Control Act* in conjunction with section 13 of the *Second Ordinance Implementing the War Weapons Control Act*. No exceptions are allowed from the obligation to mark war weapons.

The marking of firearms by industry is governed by section 13(1) through (4) of the *Weapons Act*. Arms manufacturers and arms dealers are under an obligation to warrant that—with the exceptions allowed under section 14 of the *Weapons Act*—every firearm produced, to be used, sold or imported in the area of application of the *Weapons Act* is duly, and uniquely, marked.

Section 14 of the *Weapons Act* establishes, for firearms—

- developed prior to 1871 and
- manufactured prior to January 1, 1945,

very narrow exceptions from the general marking obligation imposed on manufacturers.

If unmarked weapons not falling under section 14 of the *Weapons Act* are found, the competent authorities, as a rule, submit them to destruction, unless they constitute evidence in a criminal case under investigation or pending a final ruling, or are retained in order to be used for educational purposes of federal or state police forces.

Manufacture of unmarked or inadequately marked SALW constitutes an administrative offense pursuant to section 55(1)(5) of the *Weapons Act*.

#### 1.2.2.2 STOCKPILING

German law does not expressly regulate stockpiling of unmarked or inadequately marked SALW, but considers it to be a case to be subsumed under “possession of unmarked or inadequately marked SALW,” which constitutes an administrative offense; *see infra* [§ 1.2.2.5](#).

If unmarked weapons not falling under section 14 of the *Weapons Act* (*see supra* [§ 1.2.2.2](#)) are found, the competent authorities, as a rule, submit them to destruction, unless they constitute

evidence in a criminal case under investigation or pending a final ruling, or are retained in order to be used for educational purposes of federal or state police forces.

#### 1.2.2.3 TRANSFER AND RETRANSFER

Under section 12(7)(3) of the *War Weapons Control Act* in conjunction with section 13 of the *Second Ordinance Implementing the War Weapons Control Act* and under section 13(1) and (3) of the *Weapons Act*, all war weapons as well as firearms commercially produced in, or imported or otherwise transferred into, Germany must be marked with the sign of the producer or the importer. The mark must be of a readily recognizable and permanent nature.

Transfer of unmarked or inadequately marked SALW constitutes an administrative offense pursuant to section 55(1)(5) of the *Weapons Act*.

In case of the retransfer of SALW that have previously been imported, the original exporting state is, as a rule, notified before the retransfer of the weapons. A standardized procedure is observed in relation to States participating in the Wassenaar Arrangement; authenticated end-user certificates are used.

#### 1.2.2.4 POSSESSION

Possession of unmarked or inadequately marked SALW constitutes an administrative offense pursuant to section 55(1)(5) of the *Weapons Act*.

1.2.3 *Please describe how national laws, regulations and procedures that impact on the prevention, combating and eradication of the illicit trade in SALW in all its aspects are made public.*

#### **UNPoA II:23**

Federal, or eventually state, legislation on SALW aspects—irrespective of whether it takes the form of Act, Ordinance or Notification—is, in virtue of a constitutional principle and without any exception, published in the Federal Law Gazette (*Bundesgesetzblatt*), in the Federal Gazette (*Bundesanzeiger*) or in the state law gazettes, as the case may be.

Newer federal and state legislation is accessible on the Internet. Also English language translations of the *Basic Law*, the *War Weapons Control Act*, the *Foreign Trade and Payments Act* and relevant parts of the *Weapons Act* are easily to be found there.

SALW-related instructions addressed to the Federal Armed Forces are, as a rule, collected in the relevant manuals, which are available upon request, unless classified.

### 1.3 Law Enforcement and Criminalization

1.3.1 *What national legislative or other measures exist to make the illegal manufacture, possession, stockpiling and trade of SALW criminal offenses under domestic law? How have these measures been implemented?*

#### **UNPoA II:3**

The criminalization of illegal manufacture, possession, and trade of SALW under German law can be summarized as follows:

→ Legislative source  ↓ Offense	<i>Weapons Act</i>  applicable only on SALW not qualified as war weapons	<i>War Weapons Control Act</i>  applicable only on SALW qualified as war weapons	<i>Foreign Trade and Payments Act</i>  applicable only in cases of transboundary trade pursuant to section 1(1)
Illegal manufacture of SALW	<p><b>Section 51 (1) and 52(1)(1) in conjunction with section 2(1) or (3)</b> <i>Standard case:</i> Imprisonment (section 51(1): 1-5 years, section 52(1)(1): 6 months–5 years)</p> <p><b>Section 51(2) and 52(5)</b> <i>Major (serious) case:</i> Imprisonment (1–10 years)</p> <p><b>Section 51(3) and 52(6)</b> <i>Minor (less serious) case:</i> Imprisonment (not exceeding 3 years) or imposition of fine</p>	<p><b>Section 22a(1)(1)</b> <i>Standard case:</i> Imprisonment (1–5 years)</p> <p><b>Section 22a(2)</b> <i>Major (serious) case:</i> Imprisonment (1–10 years)</p> <p><b>Section 22a(3)</b> <i>Minor (less serious) case:</i> Imprisonment (not exceeding 3 years) or imposition of fine</p>	
Illegal possession of SALW	<p><b>Section 51(1) and 52(1)(1) in conjunction with section 2(1) or (3)</b> <i>Standard case:</i> Imprisonment (section 51(1): 1-5 years, section 52(1)(1): 6 months–5 years)</p> <p><b>Section 51(2) and 52(5)</b> <i>Major (serious) case:</i> Imprisonment (1–10 years)</p> <p><b>Section 51(3) and 52(6)</b> <i>Minor (less serious) case:</i> Imprisonment (not exceeding 3 years) or imposition of fine</p>	<p><b>Section 22a(1)(2)</b> <i>Standard case:</i> Imprisonment (1–5 years)</p> <p><b>Section 22a(2)</b> <i>Major (serious) case:</i> Imprisonment (1–10 years)</p> <p><b>Section 22a(3)</b> <i>Minor (less serious) case:</i> Imprisonment (not exceeding 3 years)</p>	
Illegal trade in SALW	<p><b>Section 51(1) and 52(1)(1) in conjunction with section 2(1) or (3)</b> <i>Standard case:</i> Imprisonment (section 51(1): 1-5 years, section 52(1)(1): 6 months–5 years)</p> <p><b>Section 51(2) and 52(5)</b> <i>Major (serious) case:</i> Imprisonment (1–</p>	<p><b>Section 22a(1)(2) and (4)</b> <i>Standard case:</i> Imprisonment (1–5 years)</p> <p><b>Section 22a(2)</b> <i>Major (serious) case:</i> Imprisonment (1–10 years)</p> <p><b>Section 22a(3)</b> <i>Minor (less serious) case:</i> Imprisonment (not exceeding 3 years)</p>	<p><b>Section 34(2) in conjunction with section 7</b> <i>Standard case:</i> Imprisonment (not exceeding 5 years) or imposition of fine —if the violation</p> <ul style="list-style-type: none"> <li>• jeopardizes Germany’s security of the Federal Republic of Germany,</li> </ul>

	10 years) <b>Section 51(3) and 52(6)</b> <i>Minor (less serious) case:</i> Imprisonment (not exceeding 3 years) or imposition of fine		<ul style="list-style-type: none"> <li>• disrupts the peaceful coexistence of nations, or</li> <li>• considerably disrupts Germany's foreign relations</li> </ul> <b>Section 34(6) in conjunction with section 7</b> <i>Major (serious) case:</i> Imprisonment (of at least 2 years) —if the violation <ul style="list-style-type: none"> <li>• entails the danger of a serious detriment to Germany's external security</li> </ul> <i>No minor (less serious) case regulation</i> See <a href="#">§ 1.3.3</a> for the legal implication if the illegal trade in SALW should violate an arms embargo imposed by the United Nations Security Council
--	--	--	---

German law does not expressly regulate illegal stockpiling, but considers it to be a case to be subsumed under “illegal possession of SALW.”

1.3.2 *Have those groups and individuals engaged in the illegal manufacture, trade, stockpiling, transfer, possession, as well as financing for acquisition, of illicit SALW been identified, where applicable? What action has been taken under appropriate national law against such groups and individuals?*

**UNPoA II:6**

See the analysis and evaluation of information available to the Federal Criminal Police Bureau on thefts, losses and seizures of SALW in 2004 in [Annex B](#).

1.3.3 *What national measures have been taken, including legal or administrative means, against activity that violates a United Nations Security Council arms embargo in accordance with the Charter of the United Nations?*

**UNPoA II:15**

For the export of military equipment, including SALW, a license is required. In case of activity that would violate an arms embargo imposed by the United Nations Security Council in accordance with the Charter of the United Nations, a license application will be dismissed. While arms embargoes, in principle, do not require transformation into municipal law, more comprehensive arrangements are in a number of cases applied and implemented in accordance with relevant EC



Council Regulations. Further, section 69g of the *Foreign Trade and Payments Ordinance* contains an additional number of specific, embargo- or destination-related prescriptions.<sup>2</sup> The terms and provisions of the relevant embargo are transposed into practice by turning down any license applications concerning the export of such goods to embargoed destinations.

In Germany, contravening embargoes imposed by the United Nations Security Council—for instance by exporting SALW to embargoed destinations—is considered a serious crime and thus consistently prosecuted. Pursuant to the first phrase of section 34(4) of the *Foreign Trade and Payments Act*, illegal trade in SALW violating such an arms embargo yields imprisonment not shorter than 2 years. In minor (less serious) cases, the custodial sanction may range between 3 months and 5 years; second phrase of section 34(4) of the *Foreign Trade and Payments Act*.

## 1.4 Stockpile Management and Security

### 1.4.1 *What national standards and procedures exist for the management and security of SALW stocks held by armed forces, police or other authorized bodies?*

#### UNPoA II:17

#### 1.4.1.1 FEDERAL ARMED FORCES

Within the Federal Armed Forces, the security of SALW stocks is governed by the following regulations:

- (i) “Guidelines Concerning the Infrastructure for Military Stockpile Facilities”
- (ii) Federal Armed Forces Regulation 2/30 “Military Security”
- (iii) Federal Army Regulation 110/100 “Military Security in the Army”

The documents referred to under (ii) and (iii) ascertain the methods for the organization and handling of, as well as procedures for, stocks, daily use and transportation of SALW. Additional regulations targeting local requirements as to achieve the requisite military security framework are also provided.

#### 1.4.1.2 FEDERAL AND STATE POLICE FORCES

The security of SALW stocks held by federal and state police forces is governed by service regulations, effectively foreclosing any access of unentitled persons. All police weaponry is centrally, and closely, registered in Federal Border Police and Federal Criminal Police Bureau records.

### 1.4.2 *How often are stocks of SALW held by armed forces, police and other authorized bodies reviewed?*

#### UNPoA II:18

#### 1.4.2.1 FEDERAL ARMED FORCES

Within the Federal Armed Forces, a distinctive control system is in use, the periodicity of which may be summarized as follows:

- (i) Guard and MP Units:  
100% inventory check at each change of shift

---

<sup>2</sup> Violations against section 69g of the *Foreign Trade and Payments Ordinance* do not constitute administrative offenses, rendering, as a rule, administrative fines.

- (ii) Combat units:  
Routine checks are carried out on a weekly basis.
- (iii) Depots and stockpile facilities:
  - Routine checks are carried out every two weeks;
  - additionally, non-periodical checks are carried out after any movement of any kind of SALW.

Periodical as well as challenge inspections carried out by higher command authorities further add to the reliability of the system.

Detailed documentation is established on every control measure.

#### 1.4.2.2 FEDERAL AND STATE POLICE FORCES

Higher command authorities carry out periodical as well as challenge inspections. Detailed documentation is established on every control measure.

#### 1.4.3 *How are those stocks of SALW held by armed forces, police and other authorized bodies that are surplus to requirements identified?*

#### **UNPoA II:18**

##### 1.4.3.1 FEDERAL ARMED FORCES

German security and defense policy is governed by values and principles as embedded, *inter alia*, in the Charter of the United Nations, in basic EU and OSCE documents, and in the *Basic Law*. Germany's national interest in the preservation of freedom, security and the welfare of its citizens, as well as in the integrity of its territory, is closely connected with her interest in a peaceful and lasting order in Europe and for the nations of the world.

For Germany, NATO remains the foundation for common defense and the primary political framework for the participation of German forces in crisis operations and peace missions. In the future, the Federal Armed Forces will also make substantial contributions to EU security operations, should NATO as a whole not be engaged. Moreover, Germany will continue to contribute to United Nations and OSCE peace missions.

Based on these political principles, the planning process regarding the structure and strength of armed forces will determine the level of surplus stocks.

##### 1.4.3.2 FEDERAL AND STATE POLICE FORCES

Not unlike the build-up of military surplus stocks, surplus of police weaponry is mainly the resultant of decisions to modernize and replace weaponry in active use or to redefine the service- or shelf-life of existing weapons. Special surplus markings on police weapons indicate that they have been removed from active service and integrated in a disposal process (*cf.* [§ 1.5.2.2 infra](#)) which is documented in the federal back-up register of SALW maintained by the Federal Border Police.

##### 1.4.3.3 FEDERAL CUSTOMS ADMINISTRATION

Surplus SALW used by customs officers are basically treated as police weaponry. Their destruction is documented in the central weapons register of the Federal Revenue Administration.

SALW seized in the course of customs controls are, upon release by the investigating authority, transferred to the central armory at the Procurement Office of the Federal Customs Administration where appropriate records are kept.

## 1.5 Collection and Disposal

1.5.1 *Please give details of any national programs that have been established and implemented for the responsible disposal of surplus stocks of SALW held by armed forces, police and other authorized bodies.*

### UNPoA II:18

#### 1.5.1.1 FEDERAL ARMED FORCES

##### 1.5.1.1.1 Introductory Remark

Interoperability within NATO permits the sale of surplus SALW to NATO countries. However, such sales have not occurred in recent years.

##### 1.5.1.1.2 Techniques for Destruction

For the reduction, demilitarization and utilization of SALW, the Federal Armed Forces mainly apply the severing (cutting) procedure, partly in combination with plastic deformation.

##### 1.5.1.1.3 Details on Recordkeeping, Authority for Destruction, and Destruction Sites

The reduction or destruction of SALW earmarked for disposal or removed from active service is conducted in four regional maintenance facilities of the Federal Armed Forces in cooperation with the German industry.

SALW earmarked for reduction are transported in a convoy protected by escort vehicles. The armed escort squad carries the records on number, type and condition of the weapons with it. A security check is performed for each weapon at the Federal Armed Forces maintenance facilities.

In the case of—

- removal from active service, serviceable parts or components are removed and stored as spare parts;
- reduction, the weapon is disassembled or the parts of it are separated according to a material separation scheme, whereupon the weapon or its parts are entirely destroyed in accordance with the planned reduction procedure, thus without keeping any spare parts.

The destruction is performed either at the Federal Armed Forces Maintenance Facility or at a German industrial facility. The disposal is documented in a protocol.

After reduction or removal from active service, each weapon is written off the Federal Armed Forces' inventory records. The documentation is kept at the Federal Armed Forces Materiel Office.

##### 1.5.1.1.4 Seized or Confiscated Weapons

SALW seized or confiscated by Federal Armed Forces outside of Germany during operations under NATO or EU control are destroyed, either through NATO or EU forces or through local

authorities. SFOR / EUFOR destroyed for example 789 pieces of SALW and KFOR 42 pieces in 2004.

#### 1.5.1.1.5 Surplus Weapons 1990—2004

Germany has reorganized its armed forces and constantly adapted its holdings of armaments and equipment to the new requirements. In 2004 the Federal Armed Forces destroyed 13.966 SALW. Consistent with national German policy the holdings of the former standard issue rifle were not sold but destroyed. Within the period 1990 to 2004 the Federal Armed Forces have destroyed a total of 1.781.696 SALW. Additional data about SALW destroyed by the Federal Armed Forces is provided in [Annex C](#).

#### 1.5.1.2 FEDERAL BORDER POLICE

Weapons seized or confiscated by the Federal Border Police are usually destroyed, hereby using the following techniques:

- meltdown in blast furnaces;
- shredding;
- torch cutting.

In the case of rare weapons, collection for the purpose of education and training of Federal Border Police forces may alternatively apply.

#### 1.5.1.3 FEDERAL CUSTOMS ADMINISTRATION

In 2004 Federal Customs Administration destroyed 370 weapons (194 pistols, 176 submachine guns) in its central repair facility for weapons. This is mainly done by severing (cutting), partly in combination with plastic deformation, by mechanical or thermal separation procedures. The destruction process is documented.

#### 1.5.2 *Is destruction the means used to dispose of such stocks?*

**UNPoA II:18**

##### 1.5.2.1 FEDERAL ARMED FORCES

Surplus SALW will be destroyed or, in a limited number of cases and on restrictive grounds, be sold. Within the Federal Armed Forces stocks declared as surplus will be transferred from the military organization to the Federal Agency for Defense Procurement and Technologies.

The main destruction method is cutting, in addition a combination of cutting and plastic deformation is also used.

##### 1.5.2.2 FEDERAL AND STATE POLICE FORCES

Destruction is the main means used by federal and state police forces to dispose of surplus stocks. However, in the case of rare weapons, these are collected for the purpose of education and training of federal and state police forces. As to pistols of caliber 9 mm\*19 mm, sale to authorized dealers is permissible.

### 1.5.2.3 FEDERAL CUSTOMS ADMINISTRATION

The Federal Customs Administration disposes of surplus stocks by employing—

- destruction;
- transfer to authorized authorities and institutions; and
- —only in the case of non-military SALW—sale to authorized dealers.

### 1.5.3 *What national measures exist to safeguard such stocks prior to their disposal?*

#### **UNPoA II:18**

#### 1.5.3.1 FEDERAL ARMED FORCES

Within the Federal Armed Forces, additional measures are not required. Surplus stocks are stored, monitored and treated on the same high standard as military SALW in active use; see [§ 1.4.1.1](#) and [§ 1.4.2.1](#) *supra*.

#### 1.5.3.2 FEDERAL AND STATE POLICE FORCES

Surplus stocks are safeguarded in the manner as police SALW in active use; see [§ 1.4.1.2](#) and [§ 1.4.2.2](#) *supra*.

#### 1.5.3.3 FEDERAL CUSTOMS ADMINISTRATION

Surplus SALW is stored in secure lockers or in secure accommodations at office level, or in the central armory at the Procurement Office of the Federal Customs Administration.

### 1.5.4 *Subject to the exceptions set out in UNPoA II:16, are all confiscated, seized or collected SALW destroyed?*

#### **UNPoA II:16**

#### 1.5.4.1 FEDERAL ARMED FORCES

SALW seized or confiscated by Federal Armed Forces outside of Germany during operations under NATO or EU control were, and are, destroyed, either through NATO, EU or U.N. forces or through local authorities.

#### 1.5.4.2 FEDERAL AND STATE POLICE FORCES

With the exception of rare weapons, which are collected for the purpose of education and training of federal and state police forces, confiscated, seized or collected SALW are, as a rule, destroyed.

#### 1.5.4.3 FEDERAL CUSTOMS ADMINISTRATION

SALW confiscated, seized or collected by customs authorities are—

- (i) transferred, as the case may be, to—

- study collections maintained by the Federal Armed Forces,
  - the Federal Criminal Police Bureau,
  - the Federal Border Police,
  - the official proof-testing agencies,
  - the Customs Criminological Office,
  - the German Customs Museum,
  - the Training Center of the Federal Revenue Administration,
  - Customs Staff Training Centers; or
- (ii) —only in the case of non-military SALW—sold to authorized dealers.

1.5.5 *What methods has your country used to destroy surplus stocks of SALW designated for destruction? (If appropriate, please make reference to the report of the U.N. Secretary-General [S/2000/1092] of November 15, 2000)*

**UNPoA II:19**

1.5.5.1 FEDERAL ARMED FORCES

Cf. [§ 1.5.1.1.2](#) *supra*.

1.5.5.2 FEDERAL AND STATE POLICE FORCES

Cf. [§ 1.5.1.2](#) *supra*.

1.5.5.3 FEDERAL CUSTOMS ADMINISTRATION

Cf. [§ 1.5.1.3](#) *supra*.

1.5.6 *Please give details of any information on SALW confiscated or destroyed within your jurisdiction that is submitted to relevant regional and international organizations.*

**UNPoA II:23**

1.5.6.1 INTRODUCTORY REMARKS

Detailed information on SALW confiscated or destroyed both within the German jurisdiction and, with the assistance of the Federal Armed Forces in the context of peace-keeping missions, overseas is regularly submitted to the Organization for Security and Cooperation in Europe (OSCE) in Annex 2 (Template for the Annual Information on SALW Identified as Surplus and/or Seized and Destroyed) to the “Information Exchange Pursuant to the OSCE Document on Small Arms and Light Weapons.” These data are available on the Internet at [www.auswaertiges-amt.de/www/de/infoservice/download/pdf/friedenspolitik/abruistung/jahresmeldung\\_klein\\_waffen.pdf](http://www.auswaertiges-amt.de/www/de/infoservice/download/pdf/friedenspolitik/abruistung/jahresmeldung_klein_waffen.pdf).

Another relevant source as to data on SALW confiscated or destroyed within Germany is the annual Schengen progress report.

1.5.6.2 FEDERAL ARMED FORCES

SALW seized or confiscated by Federal Armed Forces outside of Germany during operations under NATO or EU control are destroyed, either through NATO or EU forces or through local authorities.

#### 1.5.6.3 FEDERAL AND STATE POLICE FORCES

For the purpose of this National Report on Implementation, the Federal Criminal Police Bureau has compiled data on SALW seized in Germany in 2004. [Annex B](#) *infra* reproduces the Bureau's "Analysis and Evaluation of Information Available to the Federal Criminal Police Bureau on Thefts, Losses and Seizures of SALW in 2004."

#### 1.5.6.4 FEDERAL CUSTOMS ADMINISTRATION

The Customs Criminological Office reports the number of SALW seized each year by the Customs investigation Service to the Federal Ministry of Finance; these data are included in the annual statistics of the Federal Criminal Police Bureau and in Schengen progress reports. However, the number of SALW destroyed is not collected. Nor does the Customs Criminological Office report to international organizations.

The Procurement Office of the Federal Customs Administration, when ordering destruction or other disposal of SALW, provides information on purchasers or authorities at which the SALW will in future be held.

The Federal Ministry of Finance is supplied with information on the disposal or destruction of service SALW.

### 1.6 Export Controls and Brokering Controls

1.6.1 *Please describe the system of export and import licensing or authorization, as well as measures on international transit, used by your country for the transfer of all SALW.*

#### UNPoA II:11

#### 1.6.1.1 INTRODUCTION INTO GERMAN EXPORT CONTROL POLICY

Germany's policy on exports of military equipment is part of her foreign and security policy, which is aimed at preserving peace and stability and at warranting human rights. It corresponds to decisions on values which have been firmly entrenched across the political spectrum since the *Basic Law* was promulgated. There is a broad consensus in the Lower House of the Federal Diet (*Deutscher Bundestag*) on the legal and political foundations of Germany's policy on exports of military equipment and the restrictive approach taken by the government.

In particular, export bans adopted by the United Nations Organization or other international organizations prohibit delivery of military equipment to embargoed destinations. Such export embargoes, in order to translate them into national law, do not—contrary to other, more comprehensive arrangements—require any special legal provisions; *cf.* [§ 1.3.3](#) *supra*. The range of embargoed goods is basically identical with the military equipment as set forth in Part I section A of the *Exports Schedule*, *i.e.* the Annex to section 5(1) of the *Foreign Trade and Payments Ordinance*. In practice, the embargo provisions are transposed into practice by not granting any licenses for the export of such goods to embargoed destinations.

Decisions on the export of war weapons and other military equipment are mainly based on the *Political Principles*, adopted on January 19, 2000, (*see* [Annex A](#) *infra*) and on the relevant European

and international commitments entered into by the Federal Government, particularly on the *EU Code of Conduct on Arms Exports* adopted by the European Council on June 8, 1998.

Exports of war weapons and other military equipment both to NATO and to EU Member States as well as to “NATO equivalent countries,” such as Australia, Japan, New Zealand or Switzerland, are in line with Germany’s security interests and are, in principle, unrestricted. Exports of war weapons to third countries, in contrast, are only feasible if indicated by paramount foreign and security policy interests, bearing in mind the interests of NATO. In this context, employment aspects are not allowed to play a significant role.

The export of other military equipment is authorized to the extent that the provisions of section 7 of the *Foreign Trade and Payments Act* do not prescribe otherwise; these provisions aim to protect the security of the Federal Republic of Germany, the peaceful coexistence of nations, and foreign relations.

Decisions on exports of war weapons and other military equipment are made on the basis of a thorough examination of each case. The issue of respect for human rights in the countries of destination is a key factor in deciding whether or not to grant licenses, which is particularly true in the case of processing applications for the export of SALW. Another significant aspect is whether an armed conflict is, in fact, ongoing, or is likely between the country of destination and its neighboring states. In general, it must be certain that the military equipment will only be used for the purposes of defense and remain in the country of destination.

As politically binding instrument, the *EU Code of Conduct on Arms Exports* forms an integral part of the Political Principles of January 19, 2000, which also comprise the common export criteria set forth in section III paragraph (A) of the *OSCE Document on Small Arms and Light Weapons*.

The restrictive attitude of Germany’s export policy is reflected in the fact that military equipment represents only a minor proportion of the entirety of German exports. For example, exports of war weapons traditionally account for less than 0.5 % of all exports, and are mainly directed to countries which are members of NATO or of the OECD. This is particularly valid for SALW.

#### 1.6.1.2 TYPES OF LICENSES FOR FINAL EXPORTS

German law on foreign trade and payments defines four types of licenses for final exports:

- (i) individual licenses (see [§ 1.6.1.2.1 infra](#)),
- (ii) maximum amount licenses;
- (iii) collective export licenses (see [§ 1.6.1.2.2 infra](#)); and
- (iv) general licenses (see [§ 1.6.1.2.3 infra](#)).

As the second is only a variant of the first, they are dealt with here in a joint context.

##### 1.6.1.2.1 Individual Licenses and Maximum Amount Licenses

The basic export license is the “individual license” (*Einzelgenehmigung*). It authorizes the export of one or several pieces of equipment to one recipient upon application.

As a special type of individual license, a “maximum amount license” (*Hochstbetragsgenehmigung*) can be issued. This license permits the export of equipment for several contracts, *e.g.* in the context of a framework contract with a customer, up to the maximum amount authorized (*i.e.*, the likely sales in one year).



#### 1.6.1.2.2 Collective Export Licenses

Rather than applying for individual licenses, it is possible to issue a “collective license” (*Sammel- ausfuhrgenehmigung*) to certain exporters. This license permits the export of a group of equipment to several recipients.

#### 1.6.1.2.3 General Licenses

General Licenses are unapplicable for SALW.

#### 1.6.1.3 LICENSES FOR TEMPORARY EXPORTS

Licenses for temporary exports are issued in principle according to the same provisions and administrative proceedings as licenses for final exports. Thus, licenses for the presentation of sensitive goods on a trade fair hosted in a country considered as a critical destination may be refused. The applications for temporary exports are assessed according to the same criteria as those for final exports. The duration of a license may be distinct from usual license durations.

The only relief for the applicant is that he is not obliged to file end-user documents with the application. However, the license may provide that the exported good must be reimported to Germany. This means that the exporter must prove that the goods have been reimported to Germany upon expiration of the license. Usually, the exporter provides the Federal Agency for Economics and Export Controls with suitable documents issued by a German customs or tax authority, or with similar evidence.

Hunting arms may be temporarily exported without a license in accordance with section 19(1)(16) of the *Foreign Trade and Payments Ordinance*. However, the hunting arms must be reimported to Germany within three months. Moreover, this statutory rule provides for exemptions for certain means of transport.

Similar to temporary exports, reexports are, in general, treated according to general rules.

#### 1.6.1.4 PERIOD OF VALIDITY OF LICENSES

In general, German export licenses are valid for a time period of two years. They may only once be extended for another two years. However, individual licenses for the export of military equipment are valid only for one year; they may be extended for one additional year. The reason for this exception is that licenses for the export of military equipment are in particular subject to a political evaluation of the given circumstances which may vary in time. Thus, there is a maximum duration of validity of export licenses in case of military equipment of two years and in case of dual-use goods of four years (including possible extensions).

The proceedings for an application for extension are governed by the same strict principles as those that apply when issuing a new license.

In case of temporary exports, the duration of a license may be stipulated according to the circumstances prevailing in the individual case (*e.g.* for the duration of a trade fair).

In contrast to all other types of licenses, general licenses are issued *ex officio*. They expire at the end of a calendar year and may be extended for further calendar years.

### 1.6.1.5 LICENSING AUTHORITY AND LEGAL RECOURSE

#### 1.6.1.5.1 War Weapons

The Federal Government is the licensing authority under the *War Weapons Control Act*; section 11(1) of the said *Act*. It is authorized to assign as follows, by ordinance not requiring the consent of the Upper House of the Federal Diet (*Bundesrat*), the power to grant and cancel licenses—

- (i) for the ambit of the Federal Armed Forces: to the Federal Ministry of Defense;
- (ii) for the ambit of the Federal Customs Administration: to the Federal Ministry of Finance;
- (iii) for the ambit of the authorities or agencies responsible for maintaining law and order as well as prison authorities: the Federal Ministry of the Interior;
- (iv) for all other areas: the Federal Ministry of Economics and Labour.

Applications from companies should therefore normally be submitted to the Federal Ministry of Economics and Labour; the ministry decides on these projects in close cooperation with the Federal Foreign Office and the Federal Ministry of Defense.

While the Federal Ministry of Economics and Labour is licensing authority in routine cases not falling in the ambit of other federal ministries, it is the Federal Government, constituted as Federal Security Council, which deliberates politically contingent applications.

Following a general principle in German administrative law, applicants whose applications under the *War Weapons Control Act* are—in whole or in part—dismissed, have recourse to legal review before the administrative courts.

#### 1.6.1.5.2 Other Military Equipment

The Federal Agency for Economics and Export Controls is the licensing authority under the *Foreign Trade and Payments Act* as far as “other military equipment” is concerned; section 28(3)(1) of the said *Act*. Sensitive or significant projects are, however, regularly submitted to the Federal Ministry of Economics and Labour and the Federal Foreign Office for political assessment.

Applications for the export of *other military equipment* should be submitted to Federal Agency for Economics and Export Controls, which also decides on the applications.

Applicants whose applications under the *Foreign Trade and Payments Act* are—in whole or in part—dismissed, have ultimately recourse to legal review before the administrative courts.

#### 1.6.1.6 *Circumstances in Which a License is Not Required*

Exemptions from the obligation to obtain a license are provided for in section 19 of the *Foreign Trade and Payments Ordinance*. Thus, in the cases of exports mentioned in this provision, no license is required. Depending on the value of the transaction concerned, further exemptions may apply.

The list of exemptions set forth in section 19 of the *Foreign Trade and Payments Ordinance* comprises mainly day-to-day business matters having no major importance for export control issues.

#### 1.6.1.7 *Revocation of Licenses*

A license may be revoked if the applicant does not comply with the terms and conditions set forth in the license. If new facts occur after a license has been granted, which would have justified the denial of the license, the license may be revoked in case of a danger for public interests. The license

may also be revoked in order to prevent major damage to public interests. In certain cases the applicant may be entitled to damages, if he made use of his license in good faith before revocation.

Under specific conditions it is even possible to prohibit legal transactions and activities in individual cases. Especially exports and transfers, which could significantly disturb the peaceful coexistence between nations or seriously disrupt the Federal Republic of Germany's security or external relations (Section 2 paragraph 2, Foreign Trade and Payments Act). Section 2 paragraph 2 enables the government to take effective measures very fast in order to prevent concrete imminent danger”.

#### 1.6.1.8 *Embargoed Destinations and Areas of Concern*

See [§ 1.6.1.1](#) *supra*.

#### 1.6.1.9 *Advance Rulings*

Applying for advance rulings has turned out to be a valuable instrument in practice, as this instrument permits enterprises to foresee and to know from an early date whether they would stand a chance of obtaining the final export license needed to help the proposed deal materialize—provided, of course, that the circumstances prevailing at the date on which the inquiry was submitted have not changed. In advance rulings, the same procedural rules and material criteria apply as in ordinary license cases.

Advance rulings concerning *war weaponry* are made by the Federal Foreign Office after consultation with other Federal Ministries and Agencies, whereas cases dealing with *other military equipment* lay with the ruling authority of the Federal Agency for Economics and Export Controls. Sensitive and significant projects in the field of other military equipment are, by way of recourse, submitted to the Federal Government.

An advance ruling is legally binding upon the Federal Agency for Economics and Export Controls.

1.6.2 *Please describe the national laws, regulations and administrative procedures used by your country to ensure effective control over the export and transit of SALW. How are these measures implemented?*

#### **UNPoA II:12**

As explained in [§ 1.2.1.1](#) *supra*, German exports of military equipment (including SALW) are regulated in

- (i) the *Basic Law*, i.e. the Constitution of the Federal Republic of Germany,
- (ii) the *Act Implementing Article 26(2) of the Basic Law (War Weapons Control Act)*, and
- (iii) the *Foreign Trade and Payments Act* in conjunction with the *Foreign Trade and Payments Ordinance*.

In addition, on January 19, 2000, the Federal Government adopted “*Political Principles Governing the Export of War Weapons and Other Military Equipment*” to provide the licensing agencies with guidelines for the scope of and limits to the discretion, under which they are to act; see [Annex A](#) *infra*.

The Annex to section 1(1) of the *War Weapons Control Act*, entitled “*War Weapons Schedule*,” contains all items, which are considered to be war weapons in the understanding of the *War*

*Weapons Control Act*. Part I section A of Annex AL to section 5(1) of the *Foreign Trade and Payments Ordinance*, entitled “Exports Schedule,” contains all items, which are considered to be “other military equipment” in the understanding of the *Foreign Trade and Payments Act* and of the *Foreign Trade and Payments Ordinance*.

Defense items defined as SALW pursuant to the footnote to the third preambulatory paragraph of the *OSCE Document on Small Arms and Light Weapons* can be identified in these lists along the lines discussed in [§ 1.2.1.2](#) *supra*. SALW are mostly covered by the *War Weapons Schedule* categories, but various categories of Part I section A of the *Exports Schedule* may apply. The legal treatment of a given SALW depends on whether it constitutes “war weapon” or “other military equipment.”

Pursuant to section 6 of the *War Weapons Control Act*, there is *no legal claim to a license*. Instead, such license must be refused where war weapons threaten to be used for peace-disturbing acts, where Germany’s obligations under international public law will be violated, or where applicants are unable to prove that they are sufficiently reliable for handling war weapons. Beyond this, the issuance or refusal of an export license is subject to the political discretion of the Federal Government, and it makes use of it in line with the *Political Principles* reproduced in [Annex A](#).

The export of “other military equipment,” *i.e.* of defense items not enumerated in the *War Weapons Schedule* annexed to section 1(1) of the *War Weapons Control Act*, is subject to general export law contained in the *Foreign Trade and Payments Act* and the *Foreign Trade and Payments Ordinance*. The applicant *has a right* to receive an export license *unless* a license cannot be issued because one of the principles set forth in section 7 of the *Foreign Trade and Payments Act*—safeguarding the security of the Federal Republic of Germany; disruption to the peaceful coexistence of nations; considerable disruption to Germany’s foreign relations—would be violated. Export licenses can only be revoked under certain narrow legal preconditions; these cases occur very rarely in practice.

In certain cases, the export of other military equipment does not require an individual license. These exemptions are listed in section 19 of the *Foreign Trade and Payments Ordinance* and are discussed in more detail in [§ 1.6.1.6](#) *infra*.

Germany’s national lists are in coincidence with relevant international control lists, such as the Wassenaar Arrangement list and the EU Common List of Military Equipment, as adopted by the EU Council on June 13, 2000.

As to civilian SALW, Germany has implemented *Council Directive 91/477/EEC of June 18, 1991, on control of the acquisition and possession of weapons*<sup>3</sup> in her municipal legislation, *i.e.* in the *Weapons Act* and the *Ordinances Implementing the Weapons Act*. Pursuant to Article 12(1) of the Directive, “[t]he possession of a firearm [as defined in Annex I section II to the Directive] during a journey through two or more [EC] Member States shall not be permitted unless the person concerned has obtained the authorization of each of those Member States. Member States may grant such authorization for one or more journeys for a maximum period of one year, subject to renewal. Such authorizations shall be entered on the European firearms pass, which the traveller must produce whenever so required by the authorities of the Member States” (square brackets inserted).

### 1.6.3 Does your country use authenticated end-user certificates for this purpose?

**UNPoA II:12**

---

<sup>3</sup> Official Journal of the European Communities L 256/51 of September 13, 1991.

In order to export war weapons or other military equipment, an end-user document must normally be submitted along with the application. In the case of end-user documents, a distinction is chiefly made between—

- (i) official end-user declarations (exhibitor, government or authority of the country of destination),
- (ii) private end-user assurances (exhibitor, company or private individual), and
- (iii) International Import Certificates (IICs).

The system of end-use control is based on the above mentioned IICs and end-user documents as well as on Delivery Verification Certificates (DVCs) and import documentation provided by customs or tax authorities of third States. End-user documents do also provide for restrictions on reexport to other than the privileged States mentioned in section 3 of Annex II to *Council Regulation (EC) No. 1334/2000 of June 22, 2000, setting up a Community regime for the control of exports of dual-use items and technology*<sup>4</sup> (i.e. Australia, Canada, Japan, New Zealand, Norway, Switzerland, and the United States of America), and in case of war weapons to any State.

1.6.4 *Does your country notify the original exporting State when re-exporting or retransferring previously imported SALW?*

**UNPoA II:13**

Yes, if consented to in an official end-user declaration by the Federal Government. Should such consent not explicitly have been given, no notification will take place.

1.6.5 *What national legislation or administrative procedures exist to regulate the activities of those who engage in SALW brokering within national jurisdiction and control? (e.g. registration of brokers, licensing or authorization of brokering transactions and appropriate penalties)*

**UNPoA II:14**

1.6.5.1 LICENSES, REGISTRATION AND REPORTING

Physical transactions concerning war weapons located in Germany, including all physical transactions which are preceded by relevant brokering activities, are subject to, and covered by, licensing according to the *War Weapons Control Act*. All physical transactions of war weapons located in Germany are covered by this licensing system. Thus, all brokering activities relating to war weapons located in Germany which result in a physical transaction are covered by this licensing system.

However, as this licensing system did not cover—neither directly nor indirectly—brokering activities relating to war weapons located outside Germany, a new provision—section 4a—was inserted in the *War Weapons Control Act*, covering all weapons stated in the *War Weapons Schedule*, i.e. the Annex to section 1(1) of the *War Weapons Control Act*. According to this provision, the following activities are subject to licensing:

- mediating a contract on the acquisition or transfer of war weapons located outside German territory or showing that an opportunity exists for concluding such a contract; or
- concluding a contract on the transfer of war weapons located outside German territory.

Each individual case of arms brokering relating to war weapons located outside of Germany requires a license. Licenses are granted or denied, as the case may be, on the same conditions as export licenses.

---

<sup>4</sup> Official Journal of the European Communities L 159/1 of June 30, 2000.

The brokering activities mentioned above are, however, not subject to licensing under section 4a of the *War Weapons Control Act*, if the war weapons are to be imported into or transited through German territory in the execution of the contract.

The German law on arms brokering applies a territorial linkage test, *i.e.* it is not applicable in cases without any linkage to German territory. Thus, at least one element in the chain of brokering activities has to have ties with the German territory. This means that brokering activities normally fall under German jurisdiction if one or more of the following activities take place in Germany:

- meeting for negotiations between the interested contract parties with the participation of the broker in question; or
- making use of German telecommunication resources, *e.g.* by making telephone calls or mailing facsimiles or letters from Germany or by sending emails which are forwarded over a server located in Germany.

The fact that German citizens engage into brokering abroad without linkage to the German territory constitutes, however, no license requirement.

As the Federal Government—and upon assignment the Federal Ministry of Economics and Labour—is the licensing authority under the *War Weapons Control Act*, reference is made to [§ 1.6.1.5.1](#) which applies *mutatis mutandis* on brokering licenses.

A license for brokering may be revoked at any time. The licensing authority shall revoke a license, if, after granting the license, a reason for refusal has become evident, unless the reason is eliminated within a period of time to be determined.

There is no specific requirement for international brokers in Germany to be registered. However, since international brokers need to file an application for each of their brokering activities according to the rules explained above, authorities have good knowledge of who is currently active as an international broker.

There is no reporting requirement for international brokers in Germany.

On 23 June 2003 the Council of the European Union adopted a Common Position on the control of arms brokering (2003/468/CFSP). Regarding brokering with War Weapons the Common Position is already fully covered by section 4a *War Weapons Control Act*. At present the Federal Government is preparing to include new regulations on brokering with Other Military Equipment in the Foreign Trade and Payments Ordinance.

#### 1.6.5.2 CRIMINALIZATION OF ILLEGAL INTERNATIONAL BROKERING ACTIVITIES

The criminalization of illegal brokering in SALW under German law can handily be summarized as follows:

→ Legislative source	<i>Weapons Act</i>	<i>War Weapons Control Act</i>	<i>Foreign Trade and Payments Act</i>
↓ Offense	applicable only on SALW not qualified as war weapons	applicable only on SALW qualified as war weapons	applicable only in cases of transboundary trade pursuant to section 1(1)
Illegal brokering in SALW	<b>Section 52(1)(2)(c) in conjunction with sections 2(2) and 21(1), first phrase</b> <i>Standard case:</i> Imprisonment (6 months–5 years)	<b>Section 22a(1)(7)</b> <i>Standard case:</i> Imprisonment (1–5 years) <b>Section 22a(2)</b> <i>Major (serious) case:</i> Imprisonment (1–10 years)	

	<p>No major (serious) case regulation</p> <p><b>Section 52(6)</b> Minor (less serious) case: Imprisonment (not exceeding 3 years) or imposition of fine</p>	<p><b>Section 22a(3)</b> Minor (less serious) case: Imprisonment (not exceeding 3 years) or imposition of fine</p>	
--	---	--	--

### 1.6.5.3 EXPORTER NOT REQUIRED TO DISCLOSE BROKERS INVOLVED IN TRANSACTION

In Germany, exporters of military equipment are not legally obliged in the context of the licensing procedure to disclose whether a broker has been involved in a transaction.

### 1.6.5.4 NUMBER OF REVOCATIONS OR DISBARMENT OF INTERNATIONAL BROKERS

Since there is no formal requirement for international brokers to be registered, there is no revocation or disbarment of international brokers in Germany either. However, in case of an international broker violating German brokering law, it is conceivable that no further individual licenses will be granted to this broker.

## 1.7 Marking, Recordkeeping and Tracing

1.7.1 *Does your country require licensed manufacturers of SALW to apply an appropriate and reliable marking on each weapon as an integral part of the production process? Is this marking unique?*

### UNPoA II:7

#### 1.7.1.1 INTRODUCTORY REMARKS

All war weapons as well as firearms commercially produced in, or imported or otherwise transferred into, Germany must be marked with a unique sign of the producer or the importer. The mark must be of a readily recognizable and permanent nature.<sup>5</sup>

#### 1.7.1.2 FEDERAL ARMED FORCES

Each weapon of the Federal Armed Forces is unambiguously marked and bears the following information:

- manufacturer,
- weapon type,
- caliber,
- month and year of delivery *ex works*,
- serial number,
- proof firing stamp,
- possibly additional marks, such as, *e.g.*, maintenance information.

<sup>5</sup> For detailed technical information in English on the German system of marking of arms and weapons see § 1.1.1 and Exhibits 1.1.1:a through 1.1.1:F of the “Information Exchange Pursuant to the OSCE Document on Small Arms and Light Weapons—Annual Report 2004 Submitted by the Federal Republic of Germany,” at [www.auswaertiges-amt.de/www/de/infoservice/download/pdf/friedenspolitik/abruestung/jahresmeldung\\_kleinwaffen.pdf](http://www.auswaertiges-amt.de/www/de/infoservice/download/pdf/friedenspolitik/abruestung/jahresmeldung_kleinwaffen.pdf).

The marks are applied in accordance with the standards of applicable technical manuals.

### 1.7.1.3 FEDERAL AND STATE POLICE FORCES

Pursuant to section 13(1) of the *Weapons Act*, arms manufacturers and arms dealers are under an obligation to warrant that every firearm be marked with a sign containing data on—

- their name, a registered corporate name or a registered trademark of the arms manufacturer or arms dealer established in the area of application of the *Weapons Act*,
- the type of ammunition or—if no ammunition is used—the type of projectiles, and
- a serial number.

Under section 13(5) of the *Weapons Act*, all firearms in use with the Federal Customs Administration, the Federal Border Police and the state police forces must carry the titleholding authorities' sign.

Pursuant to section 7(1) of the *Third Weapons Ordinance 1991*, as amended, a proof firing stamp as well as a property sign—e.g. “BMI” indicating that the weapon is in use with the Federal Ministry of the Interior—are stamped or engraved on all arms used by federal authorities. For an examples of a German proof firing stamp, see [Annex D](#) *infra*.

Arms of the state police forces are marked with a state-specific sign of ownership containing an abbreviation—

- of the respective state and/or
- of the name of the institution.

E.g.: The abbreviations “HB” and “Pol.Br.” designate weapons in use with the police force of the Free Hanseatic City of Bremen, the smallest German federal state.

In the way indicated in [Annex D](#), the abbreviations “V,” “PN,” “L” and “J” are used to indicate proof firing after repair or replacement of the main parts of a firearm; section 7(2) of the *Third Weapons Ordinance 1991* and Annex II to this ordinance.

### 1.7.1.4 FEDERAL REVENUE ADMINISTRATION

In addition to the required data as described in [§ 1.7.1.2](#) *supra*, weapons in use with the Federal Revenue Administration are permanently marked with the acronym “BZV.”

### 1.7.2 *Does this marking identify the country of manufacture?*

**UNPoA II:7**

Yes, as part of the manufacturer's mark or the proof firing mark (with the stylized eagle displayed in [Annex D](#) denoting “Germany”).

### 1.7.3 *How does this marking otherwise allow concerned authorities to identify and trace the relevant weapon?*

**UNPoA II:7**

Not applicable; cf. [§ 1.7.1](#) and [§ 1.7.2](#) *infra*.



1.7.4 *How long are records kept on the manufacture, holding and transfer of SALW under your jurisdiction?*

**UNPoA II:9**

All licenseholders are obliged to keep the necessary documents for at least ten years in order to make on-site inspections of the supervising authorities possible. Such on-site inspections take place regularly and may be carried out as challenge inspections. Recordkeeping in the federal back-up register of SALW maintained by the Federal Border Police is unlimited in time, thus warranting that police weaponry can be traced even after the life-time of the weapons.

Additionally, each arms manufacturer is obliged to keep—

- (i) an arms manufacturing register (*Waffenherstellungsbuch*) and
- (ii) a register of the trade in arms (*Waffenhandelsbuch*).

These registers contain information on the production of arms, the recipients of the arms, the production numbers, and the production signs (e.g. registered trademarks or the name of the manufacturer). Upon consultation of the registers, it is possible to determine whether a specific marked arm was manufactured by the company in question. Markings may differ according to clients' wishes, but it is guaranteed that a later identification is possible.

As to non-military weapons, inspections take place once a year; they are carried out for by the competent regional administrative authority.

Concerning war weapons, companies have to observe special reporting obligations by submitting bi-annual statements to the Federal Agency for Economics and Export Controls on all registered transactions. Every second year, the Agency carries out inspections based on these statements.

1.7.5 *What national measures exist for tracing SALW held and issued by the State?*

**UNPoA II:10**

SALW held and issued by State authorities can be traced by referring the marking to—

- (i) registers kept by the Federal Armed Forces,
  - (ii) the federal back-up register of SALW maintained by the Federal Border Police,
  - (iii) the central weapons register of the Federal Revenue Administration,
- as the case may be.

A federal database collecting details on SALW which have been disposed of—i.e. transferred, destroyed, or sold—is under construction.

1.7.6 *Please give details of any steps taken by your country to cooperate in tracing illicit SALW, including the strengthening of mechanisms based on the exchange of relevant information.*

**UNPoA III:11**

1.7.6.1 FEDERAL ARMED FORCES

The Federal Armed Forces have established an effective system of cooperation with the Federal Criminal Police Bureau — and, if necessary, *via* the Bureau with Interpol — concerning theft of SALW occurring in the Federal Armed Forces.

During Peace Support Operations (PSO) the Federal Armed Forces are closely in cooperation with local authorities and/or international (i.e. UN) police forces in tracing illicit SALW.

#### 1.7.6.2 FEDERAL AND STATE POLICE FORCES

The process of tracing illicit SALW is, as a rule, initiated by a so-called tracing request forwarded by Interpol to the country of manufacture. In Germany, all measures to trace illegal SALW are undertaken by the Federal Criminal Police Bureau. If a tracing request is received by the Bureau due to indications that the weapon in question appears to be manufactured in Germany without carrying a federal or state authority marking, investigations do not only address the manufacturer (see § 1.7.4 *supra*), but even the Federal Ministry of Economics and Labor as licensing authority and the Federal Agency for Economics and Export Controls as control authority.

If the tracing request clearly indicates that the weapon in question carries a federal or state authority marking (cf. § 1.7.1 *supra*), the registers enumerated in § 1.7.5 will be consulted.

#### 1.7.6.3 FEDERAL CUSTOMS ADMINISTRATION

The customs authorities address all requests concerning identification of sale channels of illicit SALW to the Federal Criminal Police Bureau.

### 1.8 Disarmament, Demobilization and Reintegration (DD&R)

*Please describe (i) any disarmament, demobilization and reintegration (DD&R) programs your country has developed and implemented, including the effective collection, control, storage and destruction of SALW, (ii) how your country has addressed the special needs of children affected by armed conflict, in particular the reunification with their family, their reintegration into civil society, and their appropriate rehabilitation, and (iii) any DD&R programs or activities that your country has supported.*

**UNPoA II:21, II:22, II:30, II:34**

1.8.1, 1.8.2 none

#### 1.8.3 DD&R PROGRAMS OR ACTIVITIES SUPPORTED BY GERMANY

##### **Afghanistan (2004)**

In 2004, Germany has supported the DD&R process in Afghanistan by co-financing the disposal of surplus weapons and ammunition (project run by a NGO).

Germany has seconded three disarmament experts to the United Nations Assistance Mission to Afghanistan (UNAMA).

##### **Angola (1996-2003, 2003-2006)**

Germany supports the social and economic reintegration of ex-combatants and their families in Angola. Through the Instituto de Reintegração Sócio-Profissional para Ex-militares (IRSEM) Germany contributes to the World Bank led Angola Demobilization and Reintegration Programme (ADRP). The reintegration of ex-combatants is supported on the local level through socio-economic development projects and the strengthening of local government administration.

##### **Burundi (2003-2004)**

Germany supports projects for the reintegration of ex-combatants, internally displaced persons (IDPs) and returning refugees in Burundi. The German contribution consists of four main components: empowerment of communal reintegration structures, revitalization of agricultural production, income generation and rehabilitation of infrastructure.

##### **Congo, Democratic Republic (2004-2007)**

Germany supports the National Programme for Demobilisation and Reintegration (NDRP). Following support to the national Comité Technique de Planification et de Coordination (CTPC) Germany has committed funds for a three year cooperation with the Commission Nationale de Démobilisation et Réinsertion (CONADER).

### **Greater Great Lakes Region (2003-2006)**

Germany contributes to the Trust Fund of the World Bank led Multi-Country Demobilization and Reintegration Programme (MDRP) for the Greater Great Lakes Region.

### **Rwanda (2003-2006)**

Germany supports the Rwanda Demobilization and Reintegration Commission (RDRP) and the process of social reintegration of ex-combatants in Rwanda.

### **Sierra Leone (2003-2004)**

Germany supports the World Bank Trust Fund for the national demobilization program in Sierra Leone. In addition bilateral projects for the reintegration of former combattants are financed in selected regions of in Sierra Leone.

## **1.9 Awareness-Raising**

*Please describe (i) any public awareness and confidence-building programs on the problems and consequences of the illicit trade in SALW in all its aspects that your country has developed and implemented (including the public destruction of surplus weapons and the voluntary surrender of SALW) and (ii) any education and public awareness programs on the problems of the illicit trade in SALW in all its aspects that your country has encouraged.*

**UNPoA II:20, II:41**

In Germany, both media and the educational system take due note not only of the problems of illicit trade in SALW, but also of the developmental impacts connected with SALW in particular.

Germany was the first participating State in the OSCE who published its entire Information Exchange Pursuant to the OSCE Document on Small Arms and Light Weapons Report on the Internet<sup>6</sup>—an example of transparency later followed by other participating States.

## **2 REGIONAL LEVEL**

### **2.1 Legally Binding Instruments**

*2.1.1 Has your country been involved in negotiations for the conclusion of legally binding instruments aimed at preventing, combating and eradicating the illicit trade in SALW in all its aspects?*

**UNPoA II:25**

Germany participated in the elaboration of the Council Joint Action 2002/589/CFSP of July 12, 2002 on the European Union's contribution to combating the destabilising accumulation and spread of small arms and light weapons and repealing Joint Action 1999/34/CFSP,<sup>7</sup>

---

<sup>6</sup> [www.auswaertiges-amt.de/www/de/infoservice/download/pdf/friedenspolitik/abruistung/jahresmeldung\\_kleinwaffen.pdf](http://www.auswaertiges-amt.de/www/de/infoservice/download/pdf/friedenspolitik/abruistung/jahresmeldung_kleinwaffen.pdf)

<sup>7</sup> Official Journal of the European Communities L 191/1 of July 19, 2002.

Germany participated in the negotiations of the *Protocol Against the Illicit Manufacturing of and Trafficking in Firearms, Their Parts and Components and Ammunition, supplementing the United Nations Convention Against Transnational Organized Crime* (Firearms Protocol).

2.1.2 *Where such instruments exist, please describe the steps your country has taken to ratify and fully implement them.*

#### **UNPoA II:25**

Germany fully supports and implements the EU Joint Action 2002/589/CFSP. The process of ratification of the UN Firearms Protocol has been initiated.

## **2.2 Moratoria and Action Programs**

*Please give details of any support your country has given moratoria or similar initiatives on the transfer and manufacture of SALW, and/or regional action programs to prevent, combat and eradicate the illicit trade in SALW in all its aspects (including cooperation with States concerned in the implementation of these initiatives).*

#### **UNPoA II:26**

Germany fully supports and implements in her national export control decisions—

- U.N. Security Council resolutions regarding export of sensitive goods to countries subject to an (arms) embargo;
  - EU Common Positions regarding the export of sensitive goods to specific destinations;
- Germany also respects regional moratoria and is interested in a close cooperation with countries to implement them in the framework of the Wassenaar Arrangement.

## **2.3 Regional Cooperation**

2.3.1 *Please describe any involvement your country has had in the establishment of subregional or regional mechanisms with a view to preventing, combating and eradicating the illicit trade in SALW across borders (in particular trans-border customs cooperation and networks for information-sharing among law enforcement, border and customs control agencies).*

#### **UNPoA II:27**

Germany actively supported the introduction of effective export control mechanisms in acceding and associated countries in Eastern Europe and took part in both bi- and multilateral consultations. In that context, particular attention has been given to the SALW issue, including the elaboration and promulgation of new appropriate laws and the creation of an atmosphere necessary for effective law enforcement.

At subregional level, the Federal Customs Administration is involved in preventing and combatting illicit cross-border trafficking in SALW by carrying out selective checks on flows of goods not motivated by any concrete suspicion. These checks are carried out in particular by the Border Clearance and Surveillance Services and the Mobile Control Groups.

At regional level, the close cooperation between the Customs Investigation Service and the French customs administration merits to be highlighted. It includes regular special checks carried out jointly and aimed exclusively at combatting trafficking in SALW. These special checks have proved their worth over a period of many years.

The exchange of information between German, French and Austrian customs authorities is very extensive. The customs investigation services of these countries exchange intelligence on trafficking in SALW by means of prompt and unbureaucratic provision of information.

2.3.2 *Please describe any initiatives your country has undertaken to encourage regional and subregional action on illicit trade in SALW in all its aspects in order to, as appropriate, introduce, adhere, implement or strengthen relevant laws, regulations and administrative procedures.*

#### **UNPoA II:28**

Germany continues to support the intensification of the exchange, between the States participating in the *Wassenaar Arrangement*, of information on conventional weapons and especially SALW, the latter having been identified as weapons of choice of terrorists.

Germany initiated, together with Norway and The Netherlands, the OSCE principles on SALW brokering which were adopted in 2004.

The Federal Government supports the *Southern African Development Community* (SADC) in harmonizing their policies on the basis of the *SADC Protocol on the Control of Firearms, Ammunition and Other Related Material* adopted August 14, 2001. Aim of this project is to establish a National Point of Contact as envisaged in the UNPoA, to provide trainings for law enforcement agencies on SALW issues, and to support capacity building efforts within the regional police organisation SARPCCO. Moreover, the German Government has agreed to support the *East African Community* (EAC) secretariat in its effort to stem the illicit proliferation of SALW.

### **3 GLOBAL LEVEL**

#### **3.1 International Instruments Against Terrorism and Organized Crime**

*What existing international legal instruments against terrorism and transnational organized crime has your country ratified or acceded to?*

#### **UNPoA II:38**

Germany strongly supports the establishment of an international legal framework to combat all forms of terrorism. She has, thus, ratified the following treaties, including all twelve U.N. Conventions and Protocols concerning international terrorism:

- (i) European Convention on the Suppression of Terrorism, signed at Strasbourg on January 27, 1977 and the Protocol amending the European Convention on the Suppression of Terrorism on May 15, 2003;
- (ii) Convention on Offences and Certain Other Acts Committed on Board Aircraft, signed at Tokyo on September 14, 1963;
- (iii) Convention for the Suppression of Unlawful Seizure of Aircraft, signed at The Hague on December 16, 1970;
- (iv) Convention for the Suppression of Unlawful Acts against the Safety of Civil Aviation, signed at Montreal on September 23, 1971;

- (v) Convention on the Prevention and Punishment of Crimes against Internationally Protected Persons, including Diplomatic Agents, adopted by the General Assembly of the United Nations on December 14, 1973;
- (vi) International Convention against the Taking of Hostages, adopted by the General Assembly of the United Nations on December 17, 1979;
- (vii) Convention on the Physical Protection of Nuclear Material, signed at Vienna on March 3, 1980;
- (viii) Protocol on the Suppression of Unlawful Acts of Violence at Airports Serving International Civil Aviation, supplementary to the Convention for the Suppression of Unlawful Acts against the Safety of Civil Aviation, signed at Montreal on February 24, 1988;
- (ix) Convention for the Suppression of Unlawful Acts against the Safety of Maritime Navigation, done at Rome on March 10, 1988;
- (x) Protocol for the Suppression of Unlawful Acts against the Safety of Fixed Platforms Located on the Continental Shelf, done at Rome on March 10, 1988;
- (xi) Convention on the Marking of Plastic Explosives for the Purpose of Detection, signed at Montreal on March 1, 1991;
- (xii) International Convention for the Suppression of Terrorist Bombings, adopted by the General Assembly of the United Nations on December 15, 1997;
- (xiii) International Convention for the Suppression of the Financing of Terrorism, adopted by the General Assembly of the United Nations on December 19, 1999.

Germany has signed the following conventions and protocols against transnational organized crime:

- (i) UN Convention against Transnational Organized Crime of November 15, 2000;
- (ii) Protocol to Prevent, Suppress and Punish Trafficking in Persons, Especially Women and Children, supplementing the United Nations Convention against Transnational Organized Crime of November 15, 2000;
- (iii) Protocol against the Smuggling of Migrants by Land, Sea and Air, supplementing the United Nations Convention against Transnational Organized Crime of November 15, 2000;
- (iv) Protocol against the Illicit Manufacturing of and Trafficking in Firearms, Their Parts and Components and Ammunition, supplementing the United Nations Convention against Transnational Organized Crime of May 31, 2001;
- (v) UN Convention against Corruption of October 31, 2003.

Germany has, as a Member State of the Council of Europe, further ratified the following treaties relevant in the fight against organized crime:

- (i) European Convention on Mutual Assistance in Criminal Matters, signed at Strasbourg on April 20, 1959;
- (ii) Additional Protocol to the European Convention on Mutual Assistance in Criminal Matters, signed at Strasbourg on March 17, 1978;
- (iii) Convention on Laundering, Search, Seizure and Confiscation of the Proceeds from Crime, signed at Strasbourg on November 8, 1990.

Germany has signed

- (i) The Convention on Cybercrime on November 23, 2001;
- (ii) The Additional Protocol to the Convention on Cybercrime on January 28, 2003.

## 3.2 International Cooperation and Assistance

3.2.1 *Please give details of any assistance, including technical and financial assistance, your country has provided for purposes of supporting the implementation of the measures to prevent, combat and eradicate the illicit trade in SALW in all its aspects as contained in UNPoA.*

**UNPoA III:3, III:6, III:10, III:14**

In *Georgia*, the German Government supported the Caucasus Institute for Peace, Democracy and Development (CIPDD). Together with other Georgian non-governmental organisations, they aimed to enhance the knowledge about the problems of SALW in selected regions of Georgia, and to prepare civil-society actors and government authorities, both local and national, to improve the population's safety.

In *Colombia*, Germany supports the introduction of streetfootball as a means of conflict prevention in selected cities of Colombia. The project is implemented by the local NGO "Con-Texto Urbano" and the German NGO "streetfootballworld".

In *Malawi*, the German Government supports the Preparation of an information base and a strategy for small arms control in Malawi. Germany supported an assessment of the small arms situation in Malawi and the preparations for the establishment of the National Point of Contact.

In *El Salvador*, Germany supports awarenessraising on SALW problems in schools. Pupils, parents and teachers who are faced with armed violence adopt measures to curb the use of guns in schools and in private households.

In *Uganda*, Germany supports the National Focal Point on Small Arms. In accordance with the UN Program of Action on Small Arms and other regional agreements, the Ugandan government has created a bureau for the coordination of small arms control. The German Government facilitated the process to equip and consolidate the office of the bureau for small arms control.

3.2.2 *Please describe any initiatives your country has undertaken to enhance mutual legal assistance and other forms of cooperation in order to assist investigations and prosecutions in relation to the illicit trade in SALW in all its aspects.*

**UNPoA III:13**

In a broader sense, Germany has promoted the cause to facilitate legal action against the illicit trade in SALW by concluding bilateral agreements with a number of countries which contain clauses on preventing, combatting and eradicating trafficking of weapons.

3.2.3 *Please give details of any assistance your country has provided to combat the illicit trade in SALW linked to drug trafficking, transnational organized crime and terrorism.*

**UNPoA III:15**

Detailed analysis and evaluation of criminal activities implying illicit trade in SALW in Germany suggest that the often assumed linkage to drug trafficking, transnational organized crime and

terrorism cannot readily be established as to SALW-related crimes committed in Germany. Endeavors made by Germany focus therefore on respective assistance granted to neighboring European countries.

In the framework of the Stability Pact for South Eastern Europe, Germany has engaged in an intensive cooperation, at police and customs level, with different countries in the region, hereby mainly focusing on the training and specialization of border police forces as prime authorities to combat illicit trafficking in SALW.

3.2.4 *Please give details of your country's cooperation with Interpol for the purpose of identifying those groups and individuals engaged in the illicit trade in SALW in all its aspects.*

**UNPoA II:37**

Germany is closely cooperating with Interpol for the purpose of identifying those groups and individuals engaged in the illicit trade in SALW, if required in the framework of individual criminal investigations. In one case, the government of another State actively combating illicit handling of SALW has forwarded a voluminous tracing request to Germany directly, and not through Interpol, on the ground that the request did not emerge from individual criminal investigations.

3.2.5 *Please give details of your country's use and support of Interpol's International Weapons and Explosives Tracking System database (including providing relevant information on the illicit trade in SALW).*

**UNPoA III:9**

IWETS was re-named to "Interpol Weapons Electronic Tracing System", which is being developed and tested by Interpol Lyon and the USA (ATF). As soon as a workable version exists, it will be put at the disposal of the member states.

3.2.6 *Please give details of your country's cooperation with the U.N. system to ensure the effective implementation of arms embargoes decided by the U.N. Security Council in accordance with the U.N. Charter.*

**UNPoA II:32**

Both in her national decision-making process related to all export and brokering control matters and in the practice of her courts, Germany fully supports and implements arms embargoes decided by the U.N. Security Council in accordance with the U.N. Charter.

As has been emphasized in [§ 1.3.3](#) and [§ 1.6.1.1](#) *supra*, the competent authorities will inevitably dismiss license applications, if there is ground to believe, in the individual case, that the envisaged activity would violate an arms embargo imposed by the U.N. Security Council in accordance with the U.N. Charter. While arms embargoes, in principle, do not require transformation into municipal law, more comprehensive arrangements are in a number of cases applied and implemented in accordance with relevant EC Council Regulations. Further, section 69g of the *Foreign Trade and Payments Ordinance* contains an additional number of specific, embargo- or destination-related prescriptions.<sup>8</sup> The terms and provisions of the relevant embargo are

---

<sup>8</sup> Violations against section 69g of the *Foreign Trade and Payments Ordinance* do not constitute criminal, but rather administrative offenses, rendering, as a rule, administrative fines.



transposed into practice by turning down any license applications concerning the export of such goods to embargoed destinations.

In Germany, contravening embargoes imposed by the United Nations Security Council, for instance by exporting SALW to embargoed destinations, is considered a serious crime and thus consistently prosecuted. Pursuant to the first phrase of section 34(4) of the *Foreign Trade and Payments Act*, illegal trade in SALW violating such an arms embargo yields imprisonment not shorter than 2 years. In minor (less serious) cases, the custodial sanction may range between 3 months and 5 years; second phrase of section 34(4) of the *Foreign Trade and Payments Act*.

3.2.7 *Please describe any steps your country has taken in cooperation with other states, or regional or international organizations, to develop common understandings of the basic issues and the scope of the problems related to illicit brokering in SALW.*

**UNPoA II:39**

Germany, in cooperation with Norway, has drafted the chapter on brokering in the OSCE Best Practice Guide on Small Arms and Light Weapons.

Germany initiated, together with Norway and The Netherlands, the OSCE principles on SALW brokering which were adopted in 2004.

Germany is participating in the broad based consultations the United Nations organize on brokering.

### **3.3 Cooperation with Civil Society and Nongovernmental Organizations**

*Please give details of cooperation with civil society and nongovernmental organizations in activities related to the prevention, combat and eradication of the illicit trade in SALW in all its aspects, at the national, regional and global levels.*

**UNPoA II:20, 40, 41; III.2, 18**

The German Federal Government has been cooperating with NGOs on small arms control on the projects mentioned under I.8.3. and III.2.i. namely, these are:

- The HALO Trust (UK)
- Caucasus Institute for Peace, Democracy and Development (CIPDD, Georgia);
- Centre for Human Rights and Rehabilitation (CHRR, Malawi);
- Georgian Association of Euro-Atlantic Partnership (GAEAP, Georgia)
- Latin American Institute for Social Research (FLACSO, El Salvador);
- SaferAfrica (South Africa);
- Saferworld (UK)
- streetfootballworld (Germany);
- Swedish Fellowship of Reconciliation (SweFOR, Sweden).
- Working Group for Weapons Reduction (WGWR, Cambodia);

All activities relate to awareness raising and public relations work.

### **3.4 Information Exchange**

3.4.1 *Please describe any steps taken by your country to exchange information on national marking systems on SALW.*

**UNPoA III:12**

For detailed technical information in English on the German system of marking of arms and weapons see [Annex D](#) as well as § 1.1.1 and Exhibits 1.1.1:A through 1.1.1:F of the “Information Exchange Pursuant to the OSCE Document on Small Arms and Light Weapons” at [www.auswaertiges-amt.de/www/de/infoservice/download/pdf/friedenspolitik/abruestung/jahresmeldung\\_klein\\_waffen.pdf](http://www.auswaertiges-amt.de/www/de/infoservice/download/pdf/friedenspolitik/abruestung/jahresmeldung_klein_waffen.pdf) (cf. § 1.7.1 *supra*).

3.4.2 *Please give details of any information on, inter alia, SALW confiscated or destroyed within national jurisdiction, or other relevant information such as illicit trade routes and techniques of acquisition, that your country has submitted to relevant regional and international organizations.*

**UNPoA II:23**

Detailed information on SALW confiscated or destroyed both within the German jurisdiction and, with the assistance of the Federal Armed Forces in the context of peace-keeping missions, overseas is regularly submitted to the OSCE in Annex 2 (Template for the Annual Information on SALW Identified as Surplus and/or Seized and Destroyed) to the “Information Exchange Pursuant to the OSCE Document on Small Arms and Light Weapons—Annual Report 2004 Submitted by the Federal Republic of Germany.” These data are available on the Internet at [www.auswaertiges-amt.de/www/de/infoservice/download/pdf/friedenspolitik/abruestung/jahresmeldung\\_klein\\_waffen.pdf](http://www.auswaertiges-amt.de/www/de/infoservice/download/pdf/friedenspolitik/abruestung/jahresmeldung_klein_waffen.pdf).

The annual statistics of the Federal Criminal Police Bureau include the number of seizures made by the Customs Investigation Service (cf. § 1.5.6.4 *supra*).

### **3.5 Training, Capacity-Building, Research**

3.5.1 *Please describe any initiatives your country has undertaken to enhance cooperation and exchange of experience and training among competent officials, including customs, police, intelligence and arms control officials, at the national, regional and global levels in order to combat the illicit trade in SALW in all its aspects.*

**UNPoA III:7**

In 2004 Federal Armed Forces officers contributed to several seminars and workshops on SALW related issues, i.e. in Moldova, Turkmenistan, Albania and Uganda. The commitments focussed mainly on stockpile security, marking and tracing of SALW and the illicit trade in SALW.

As mentioned under II.3.ii, the German Government is supporting the Southern African Development Community (SADC) in their efforts to stem the illicit trade of SALW in the region. Particularly, trainings for law enforcement agencies on SALW issues and capacity building measures within the regional police organisation SARPPCO are envisaged.

The German Government supports the League of Arab States (LAS) in building up a regional SALW focal point. It also financed the translation into Arabic of the OSCE Handbook of Best Practices.

3.5.2 *Please describe any regional and international programs for specialist training on small arms stockpile management and security that your country has developed or supported.*

**UNPoA III:8**

In the framework of the Stability Pact for South Eastern Europe, the Federal Border Police have responded to demands from different countries in the region so as to cooperate in the fields of training and specialization of border police forces as prime authorities to combat illicit trafficking in SALW.

Germany has provided financial and expert support to seminars on border security, SALW marking and stockpile management, conducted under the auspices of the OSCE, in Termiz (Uzbekistan) and in Zagreb (Croatia).

3.5.3 *Please give details of any action-oriented research aimed at facilitating greater awareness and better understanding of the nature and scope of the problems associated with the illicit trade in SALW in all its aspects that your country has developed or supported.*

**UNPoA III:18**

Germany sponsors a project by the Bonn International Center for Conversion (BICC) that aims at the development of a range of ready-to-teach courses on various aspects of small arms action for a variety of target groups in developing countries. The project is accessible at <http://www.tresa-online.org/>.

## ANNEX A POLITICAL PRINCIPLES GOVERNING THE EXPORT OF WAR WEAPONS AND OTHER MILITARY EQUIPMENT, ADOPTED ON JANUARY 19, 2000

The Government of the Federal Republic of Germany, desiring

- to pursue a restrictive policy on arms exports,
- with regard to the international and statutory obligations of the Federal Republic of Germany regarding exports of war weapons and other military equipment to countries,
- through the restriction and control of such exports to contribute to safeguarding peace, preventing the threat or use of force, securing respect for human rights and promoting sustainable development in all parts of the world,
- hence to take account also of decisions adopted by international institutions with a view to disarmament and designed to restrict the international arms trade,
- to press for such decisions to be made legally binding at the international as well as at the European level,

has modified its principles for the export of war weapons and other military equipment as follows:

### I. General Principles

1. The Federal Government's decisions regarding the export of war weapons<sup>9</sup> and other military equipment<sup>10</sup> are made in accordance with the provisions of the *War Weapons Control Act* and the *Foreign Trade and Payments Act* as well as the *EU Code of Conduct for Arms Exports* adopted by the European Council on June 8, 1998, and such arrangements as may be agreed subsequently as well as the *Principles Governing Conventional Arms Transfers* adopted by the Organization for Security and Cooperation in Europe (OSCE) on November 25, 1993. The criteria laid down in the *EU Code of Conduct for Arms Exports* are an integral part of these Policy Principles. The standards stipulated in the Code of Conduct will be superseded by any more stringent standards that may be derived from the following principles:
2. The issue of respect for human rights in the countries of destination and end-use is a key factor in deciding whether or not to grant licenses for the export of war weapons and other military equipment.
3. On principle export licenses for war weapons and other military equipment will not be granted where there are reasonable grounds to suspect that they will be used for internal repression as defined in the *EU Code of Conduct for Arms Exports* or the sustained and systematic abuse of human rights. In this context the assessment of the human rights situation in the recipient country is an important factor to be considered.
4. Such assessments will take into account the views of the European Union, the Council of Europe, the United Nations (U.N.), the OSCE and other international bodies. Reports issued by international human rights organizations will also be taken into consideration.

---

<sup>9</sup> Weapons (complete weapons as well as components classed separately as weapons) listed in the *War Weapons Schedule* (Annex to the *War Weapons Control Act*).

<sup>10</sup> Goods specified in Part I section A of the *Exports Schedule* (Annex to the *Foreign Trade and Payments Act*) with the exception of war weapons.

5. The end-use of war weapons and other military equipment must be definitively determined.

## II. NATO Countries,<sup>11</sup> EU Member States, Countries with NATO-Equivalent Status<sup>12</sup>

1. The export of war weapons and other military equipment will be geared to the security interests of the Federal Republic of Germany with regard to the Alliance and the European Union.

In principle, such export will not be restricted unless in specific cases this is warranted on particular political grounds.

2. Cooperative ventures in this area should be in the interest of the Alliance and/or European policy.

In the case of coproduction projects covered by intergovernmental agreements with countries referred to in this section, these arms export principles will be given practical effect as far as possible. While mindful of its special interest in its cooperation standing, the Federal Government will not forgo any opportunities it may have to influence export projects envisaged by its cooperation partners (Section II[3]).

3. Before concluding any cooperation agreement, a timely joint assessment of its export policy implications is to be made.

To give effect to its arms export policy principles, the Federal Government reserves the right by way of consultations to object to particular export projects envisaged by its cooperation partners. All new cooperation agreements should therefore aim in principle to incorporate a consultations procedure enabling the Federal Government to raise effectively any objections it might have to exports envisaged by its partner country. In doing so the Federal Government will seek, in the light of the human rights criterion, to strike a balance between its interest in cooperation and its fundamentally restrictive arms export policy.

4. Before any exports of war weapons or other military equipment involving German components take place, the Federal Foreign Office, the Federal Ministry of Economics and Labour and the Federal Ministry of Defense, in conjunction with the Federal Chancellery, will evaluate whether in any specific case the relevant conditions for initiating such consultations exist.

The Federal Government will raise objections—generally following consideration of the matter by the Federal Security Council—against such exports involving the use of German components in the following cases:

- exports to countries involved in an armed conflict, unless such conflict is covered by Article 51 of the UN Charter,
- exports to countries where an outbreak of armed conflict is imminent or where exports may stir up, perpetuate or exacerbate latent tensions and conflicts,
- exports where there are reasonable grounds to suspect that they may be used for internal repression as defined by the EU Code of Conduct for Arms Exports or the sustained and systematic abuse of human rights,
- exports that would impair the vital security interests of the Federal Republic of Germany,
- exports that would impose such a strain on relations with third countries that even Germany's own interest in the cooperative venture and in maintaining good relations with its cooperation partner must rank second.

---

<sup>11</sup> Area of application of Article 6 of the NATO Treaty.

<sup>12</sup> Australia, Japan, New Zealand, Switzerland.

Objections will not be raised if in the light of the considerations outlined in Section III(4) to (7) below licenses for the export of direct deliveries of war weapons and other military equipment are likely to be granted.

5. In the case of cooperative ventures between German companies and companies in countries referred to in Section II above not covered by intergovernmental agreements, supplies of components will, as with direct deliveries of war weapons and other military equipment, in principle not be restricted. The Federal Government will, however, as in the case of cooperative ventures covered by intergovernmental agreements, bring its influence to bear in the matter of exports resulting from cooperative ventures between commercial companies.

To that end it will require German cooperative venture partners to enter a contractual obligation that, should they supply components of a quantity or type that could be relevant to the manufacture of war weapons, they will inform the Federal Government in good time as to their partners export intentions and seek legally binding arrangements on end-use.

6. In the case of German supplies of components (separate components or subsystems) that constitute war weapons or other military equipment, the partner country is in terms of exports law both purchaser and user. Where such components are built into a weapons system as fixed features, that process in terms of exports law makes the partner country the country of origin of the goods in question.

### III. Other Countries

1. A restrictive policy will be pursued regarding exports of war weapons and other military equipment to countries other than those covered by Section II. Notably the development of additional, specifically export-oriented must be avoided. The Federal Government will not take the initiative to privilege any specific country or region.
2. Export licenses for war weapons (subject to licensing under the *War Weapons Control Act* and the *Foreign Trade and Payments Act*) will not be granted unless in a specific case this is exceptionally warranted on particular foreign and security policy grounds, having due regard to Alliance interests. Labor policy considerations must not be a decisive factor.
3. Export licenses for other military equipment (subject to licensing under the *Foreign Trade and Payments Act*) will be granted only where such exports will not prejudice interests that German law on foreign trade and payments serves to protect, namely, security, peace among the nations and Germany's foreign relations.

The protection of these interests takes priority over economic interests as defined in Section 3(1) of the *Foreign Trade and Payments Act*.

4. Export licenses pursuant to the *War Weapons Control Act* and/or the *Foreign Trade and Payments Act* will not be granted where the internal situation in the country concerned precludes such action, e.g. in the case of armed conflict or where there are reasonable grounds for suspecting such exports may be used for internal repression or the sustained and systematic abuse of human rights. In this context the human rights situation in the recipient country is a major factor to be considered.

5. No licenses will be granted for the export of war weapons and other military equipment related to war weapons<sup>13</sup> to countries—
  - involved in armed conflict or where armed conflict is imminent,
  - where the outbreak of armed conflict is imminent or where such exports would stir up, perpetuate or exacerbate latent tensions and conflicts.Exports to countries involved in external armed conflicts or where there is a danger such conflicts may erupt are therefore ruled out on principle except in cases covered by Article 51 of the U.N. Charter.
6. Decisions on whether to grant export licenses for war weapons and other military equipment will take into account whether sustainable development in the recipient country is being seriously impeded by excessive arms spending.
7. Also to be taken into account is the recipient country's conduct in terms of whether it—
  - supports and promotes terrorism and international organized crime,
  - complies with international obligations, especially renunciation of the threat or use of force, including obligations under humanitarian law on international or non-international conflicts,
  - has assumed obligations in the area of non-proliferation and other aspects of arms control and disarmament, notably by signing, ratifying and implementing the arms control and disarmament arrangements specified in the *EU Code of Conduct for Arms Exports*,
  - supports the U.N. Register of Conventional Arms.

#### IV. Definitive Determination of End-Use

1. Export licenses for war weapons and other military equipment will be granted only on the basis of prior knowledge of definitive end-use in the country of final destination.

This will generally require a written assurance by the end-user as well as other appropriate documentation.
2. Export licenses for war weapons or other military equipment of a quantity and type relevant to war weapons may be granted only on the presentation of governmental end-use certificates that preclude re-exports without prior authorization. This applies *mutatis mutandis* to any other military equipment related to war weapons exported in connection with a manufacturing license. For the export of such equipment used for the manufacture of war weapons definitive end-use certificates must be furnished.

Stringent standards are to be applied in assessing whether the recipient country is capable of carrying out effective export controls.
3. War weapons and other military equipment relevant to war weapons may only be re-exported to third countries or transferred inside the EU Internal Market with the written approval of the Federal Government.
4. A recipient country that, in breach of an end-use certificate, authorizes or does not seek to prevent or sanction the unauthorized re-export of war weapons or other military equipment relevant to war weapons will on principle, as long as such conditions persist, be excluded from

---

<sup>13</sup> Plant and documentation for the manufacturer of war weapons.



receiving any further deliveries of war weapons or other military equipment related to war weapons.

## **V. Arms export report**

The Federal Government will submit to the German *Bundestag* an annual report on the principle and practice of its arms exports policy listing, with details of the relevant legislation, the export licenses for war weapons and other military equipment it has granted over the past year.

## ANNEX B ANALYSIS AND EVALUATION OF INFORMATION AVAILABLE TO THE FEDERAL CRIMINAL POLICE BUREAU ON THEFTS, LOSSES AND SEIZURES OF SALW IN 2004

### B.1 Introductory Remark

Federal statistics on weapons-related criminality focus on the category of crimes and on seizures. It does, however, not cover data on the number of suspects, accused or convicted persons.

Due to the changes in data processing, it was not possible to gather conclusive statistical figures for the year 2003. Data for 2001 and 2002 were reported in 2003 and 2004.

### B.2 Thefts and Losses

In 2004, two submachine guns were reported stolen and no SALW were registered as lost.

### B.3 Seizures

In 2004, 191 cases of SALW seizures have been registered in the Federal Criminal Police Bureau's central database, comprising the following quantities:

#### SALW Seizures in 2004

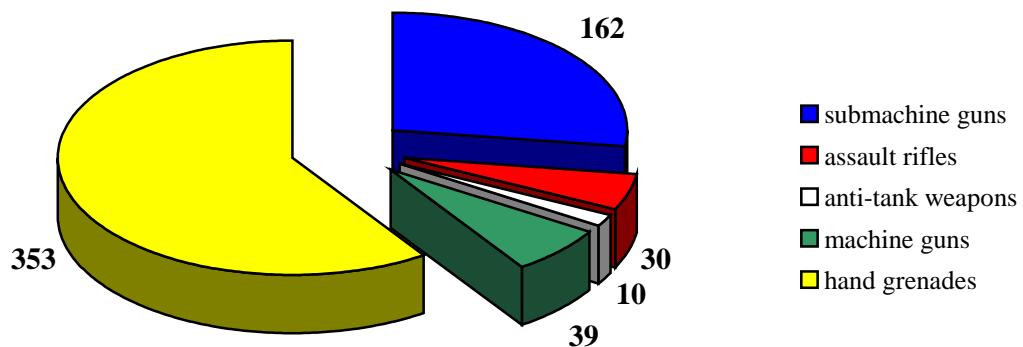

Four of the 162 seized submachine guns, one of the seized handgrenades and two of the 30 assault rifles were confiscated in the course of investigations relating to criminal offenses according to the German Penal Code. 184 pieces of the seized handgrenades were of Russian respectively Yugoslavian origin. No anti-tank weapon could doubtlessly be related to a specific country of production.

In 2004, 81 submachine guns, 9 machine guns and 24 assault rifles were seized which could doubtlessly be related to a specific country of manufacture. 117 pieces of the total amount of 231 seized weapons could, however, not unambiguously be related to a specific country of production:

**SALW Seizures in 2004 According to Country of Manufacture**

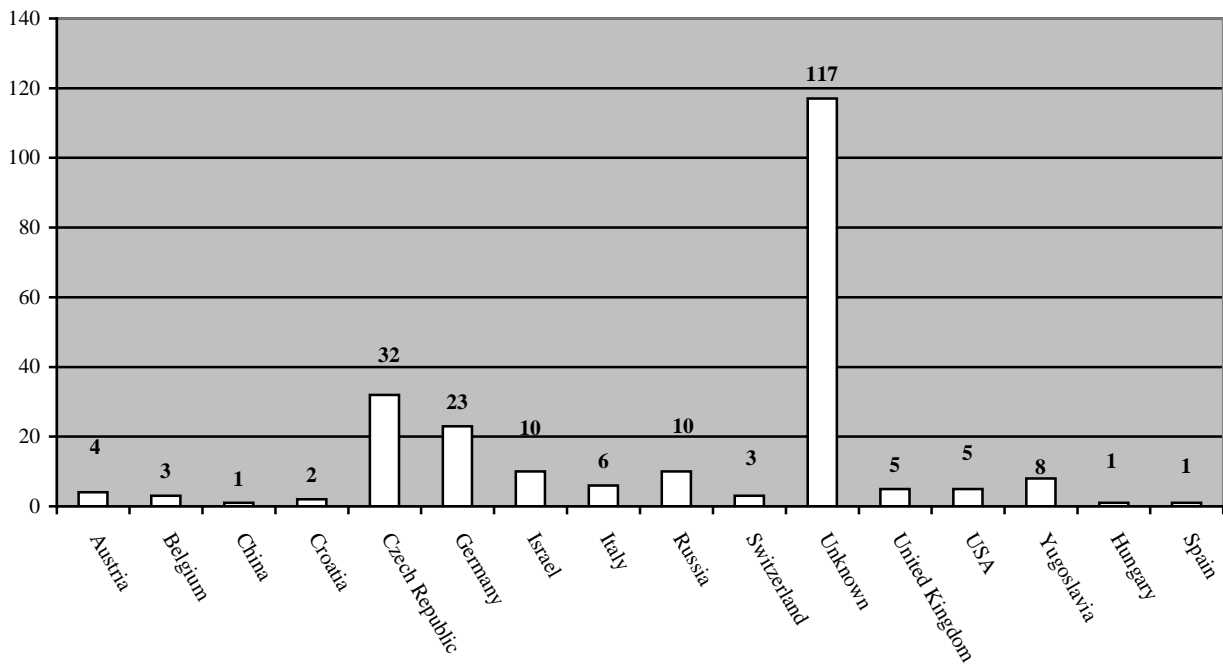

The illegally used and seized SALW of international producers were modern military items, currently used in armed forces of several countries. The seized weapons of German origin were almost without exemption produced before 1945.

The results of the evaluation prove that the German legislation aiming at the control of war weapons and war material is effective and strict. Weapons of German origin do not play a relevant part in the field of criminality. It is, on the contrary, weaponry manufactured abroad and illicitly brought into Germany which constitutes the major problem.

#### **B.4 Illicit Trafficking**

1.6 % of the cases involving seizure of SALW in 2004 were prosecuted as illicit trafficking.

#### **B.5 Illicit Manufacture**

0.5 % of the cases involving seizure of SALW in 2004 were prosecuted as illicit manufacture.

## ANNEX C

### Number of Federal Armed Forces SALW destroyed in the period 2000 to 2004

After having accomplished the destruction program concerning weapon systems of the former National People's Army of the German Democratic Republic, the Federal Armed Forces have demilitarized the following numbers of SALW in the listed categories:

Year	2000	2001	2002	2003	2004
<b>Small arms</b>					
Revolvers and self-loading Pistols	1207	1702	156	55	1.975
Rifles and carbines	35407	24743	89189	175151	8820
Sub-machine guns	403	0	1299	2599	20
Assault rifles	0	0	0	0	0
Light machine guns	863	0	338	739	1369
<b>Light weapons</b>					
Heavy machine guns	0	0	0	0	0
Hand-held, under-barrel and mounted grenade launchers	0	0	94	864	441
Portable anti-aircraft guns	0	0	0	3	0
Portable anti-tank guns	0	0	0	0	0
Recoilless rifles			6493	11900	1341
Heavy machine guns	0	0	0	0	0
<b>Total</b>	<b>37.880</b>	<b>26.445</b>	<b>97.569</b>	<b>191.311</b>	<b>13.966</b>

## ANNEX D LOCATION AND SAMPLE OF MARKS

Sample proof firing mark

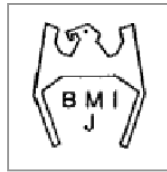

Location of marks

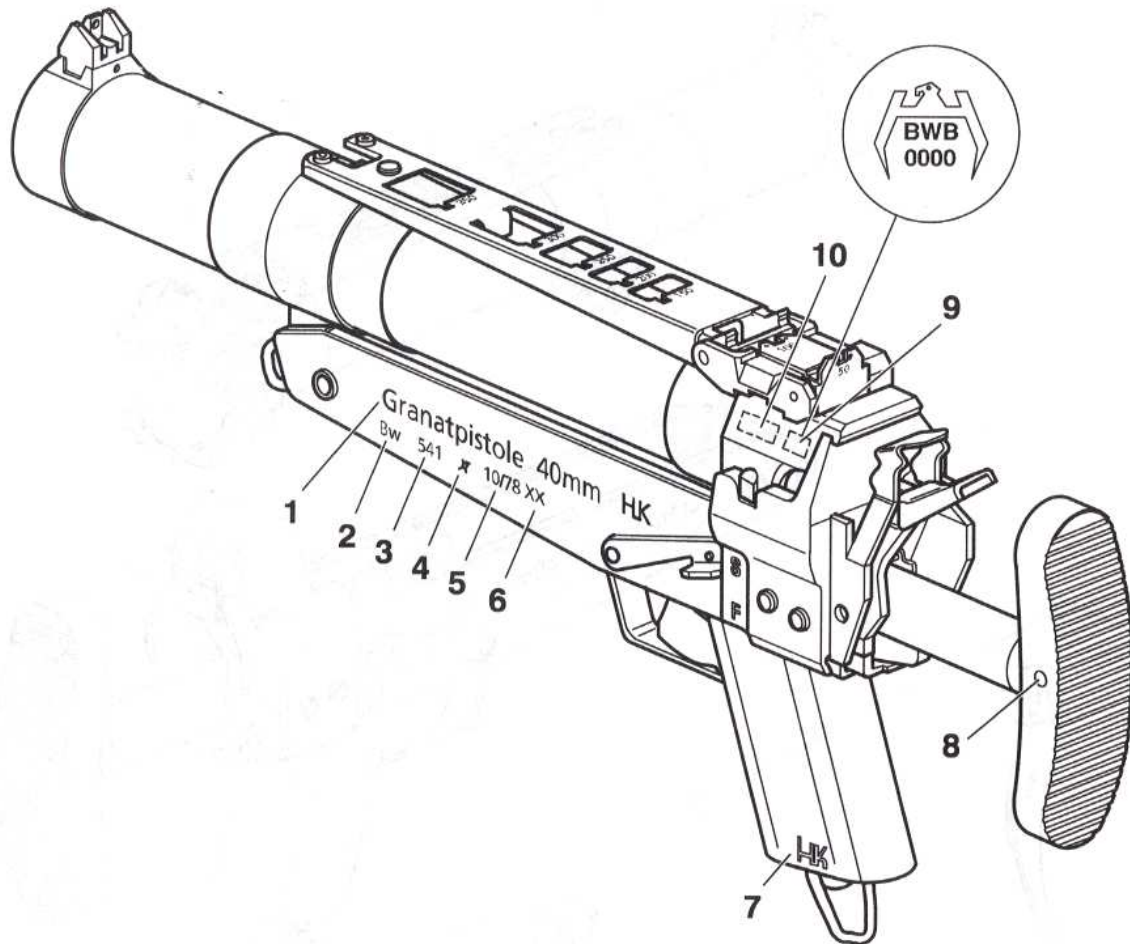

- 1 Type designation
- 2 Property stamp
- 3 Manufacturing no.
- 4 Asterisk for system maintenance center
- 5 Month/year of manufacturing (right-hand side: month/year of major repair, monogram of maintenance center)
- 6 Proof firing stamp/inspection stamp
- 7 Manufacturer's stamp
- 8 Mark for modified catch
- 9 Proof firing stamp
- 10 Last 3 digits of item no.